

Product data

Vertical Multistage Centrifugal In-line Pumps



STAIRS

50Hz

Range	SB, SBI, SBN					
	32	45	64	90	120	150
50Hz						
Nominal flow [m ³ /h]	30	45	64	90	120	150
Flow range [m ³ /h]	15-40	22-58	30-85	45-120	60-160	75-180
Max. pressure [bar]	27.5	33	21.8	20	20.4	18.7
Fluid temperature [°C]	-15 to +120					
Motor power [kW]	1.5-30	3-45	4-45	5.5-45	11-75	11-75
Version						
SB: Cast iron and stainless steel EN 1.4301/AISI 304	•	•	•	•	•	•
SBI: Stainless steel EN 1.4301/AISI 304	•	•	•	•	•	•
SBN: Stainless steel EN 1.4401/AISI 316	•	•	•	•	•	•
Motor						
Mains connection 1- [V/Hz] (Permissible voltage tolerance ± 10%)	0.37-2.2 kW 220-240 V					
Mains connection 3- [V/Hz] (Permissible voltage tolerance ± 10%)	0.37-2.2 kW 220-240 V / 380-415 V 3 - 22 kW 220-240 V / 380-415 V 3 - 22 kW 380-415 V / 660-720 V 30 - 75 kW 380-415 V / 660-720 V					
Insulation class	F					
Enclosure class	IP 55					
Ambient temperature	50 °C					
SB, SBI, SBN Pipe Connection						
Flange	DN 65	DN 80	DN100	DN100	DN125	DN125
SBI, SBN Pipe Connection						
Victaulic-connections	N/A	N/A	N/A	N/A	N/A	N/A
Mechanical Seals						
SiC/SiC	Standard					
Seals						
EPDM	Standard				0.37kW-45kW	
Viton					55kW-75kW	

* Flange standards : Refer to dimensional drawings

Construction

Vertical Multistage Centrifugal In-line Pumps



STAIRS

SB-32,45,64,90

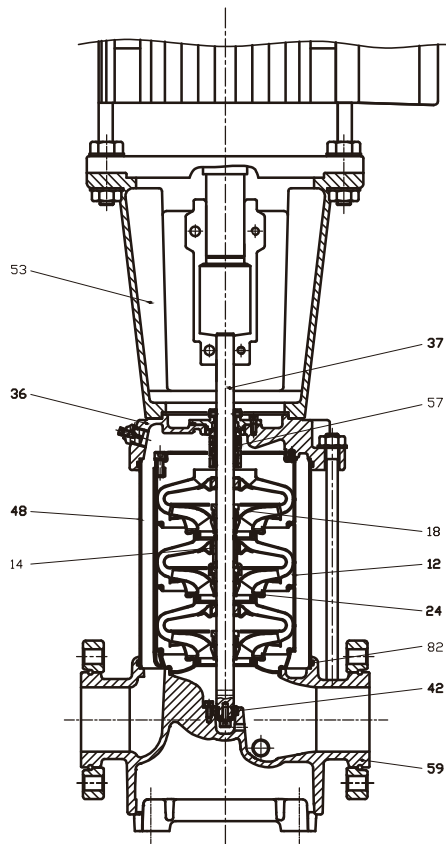

SBI(N)-32,45,64,90

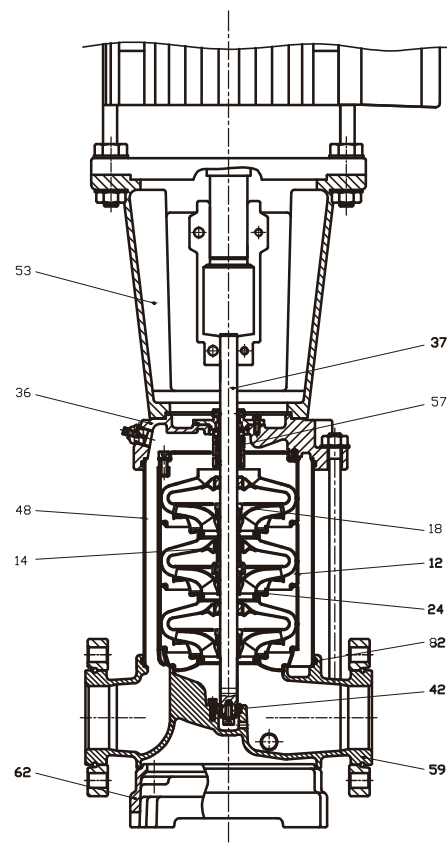

CONSTRUCTION

Pos.	Name	Material	SB 32, 45, 64, 90		SBI 32, 45, 64, 90		SBN 32, 45, 64, 90	
			Standard		Standard		Standard	
			Europe	USA	Europe	USA	Europe	USA
36	Pump head	Cast Iron	EN-GJL-250	ASTM 35B				
		Stainless steel			1.4301	AISI 304	1.4401	AISI 316
53	Motor Bracket	Cast Iron	EN-GJL-250	ASTM 35B	EN-GJL-250	ASTM 35B	EN-GJL-250	ASTM 35B
18	Impeller	Stainless steel	1.4301	AISI 304	1.4301	AISI 304	1.4401	AISI 316
37	Shaft	Stainless steel	1.4057	AISI 431	1.4057	AISI 431	1.4401	AISI 316
48	Outer Sleeve	Stainless steel	1.4301	AISI 304	1.4301	AISI 304	1.4401	AISI 316
82	O-ring for outer sleeve	EPDM						
12	Chamber	Stainless steel	1.4301	AISI 304	1.4301	AISI 304	1.4401	AISI 316
24	Neck ring	Carbon Fiber + POB + PTFE						
59	Base	Cast Iron	EN-GJL-250	ASTM 35B	N/A			
	Base	Stainless steel	N/A		1.4301	AISI 304	1.4401	AISI 316
62	Base plate	Cast Iron	N/A		EN-GJL-250	ASTM 35B	EN-GJL-250	ASTM 35B
57	Mechanical seal	Cartridge type						
14	Bearing ring		Bronze				POB+Graphite+PTFE	
42	Bottom bearing ring	Tungsten carbide/ Tungsten carbide						

Performance Curves

Vertical Multistage Centrifugal In-line Pumps

SB(I/N) 90



STAIRS

SB, SBI, SBN 90

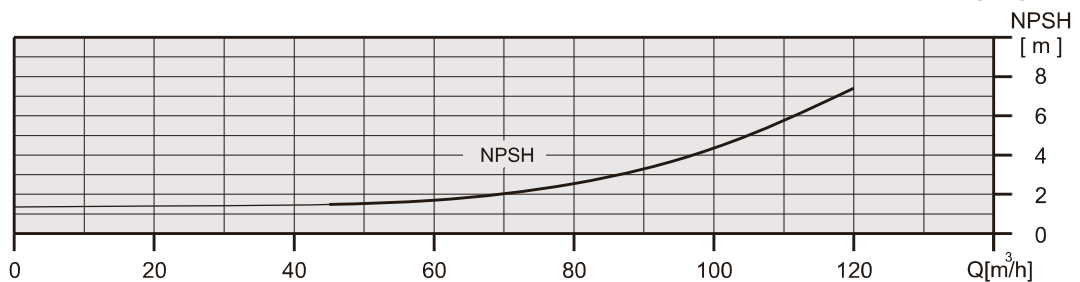
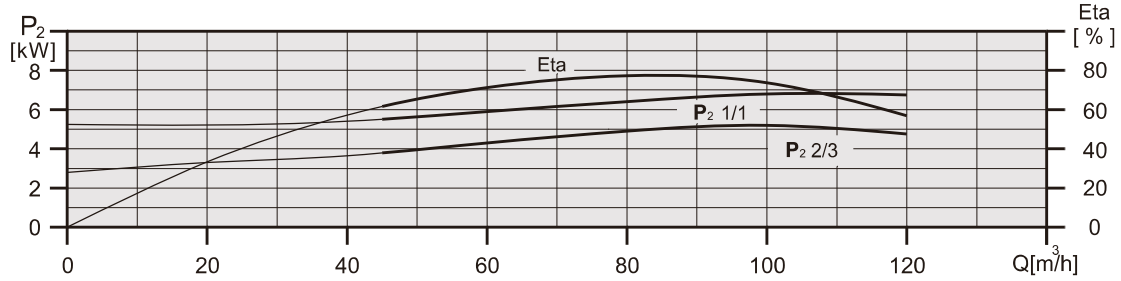
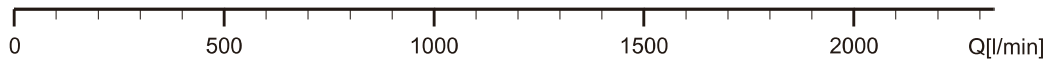
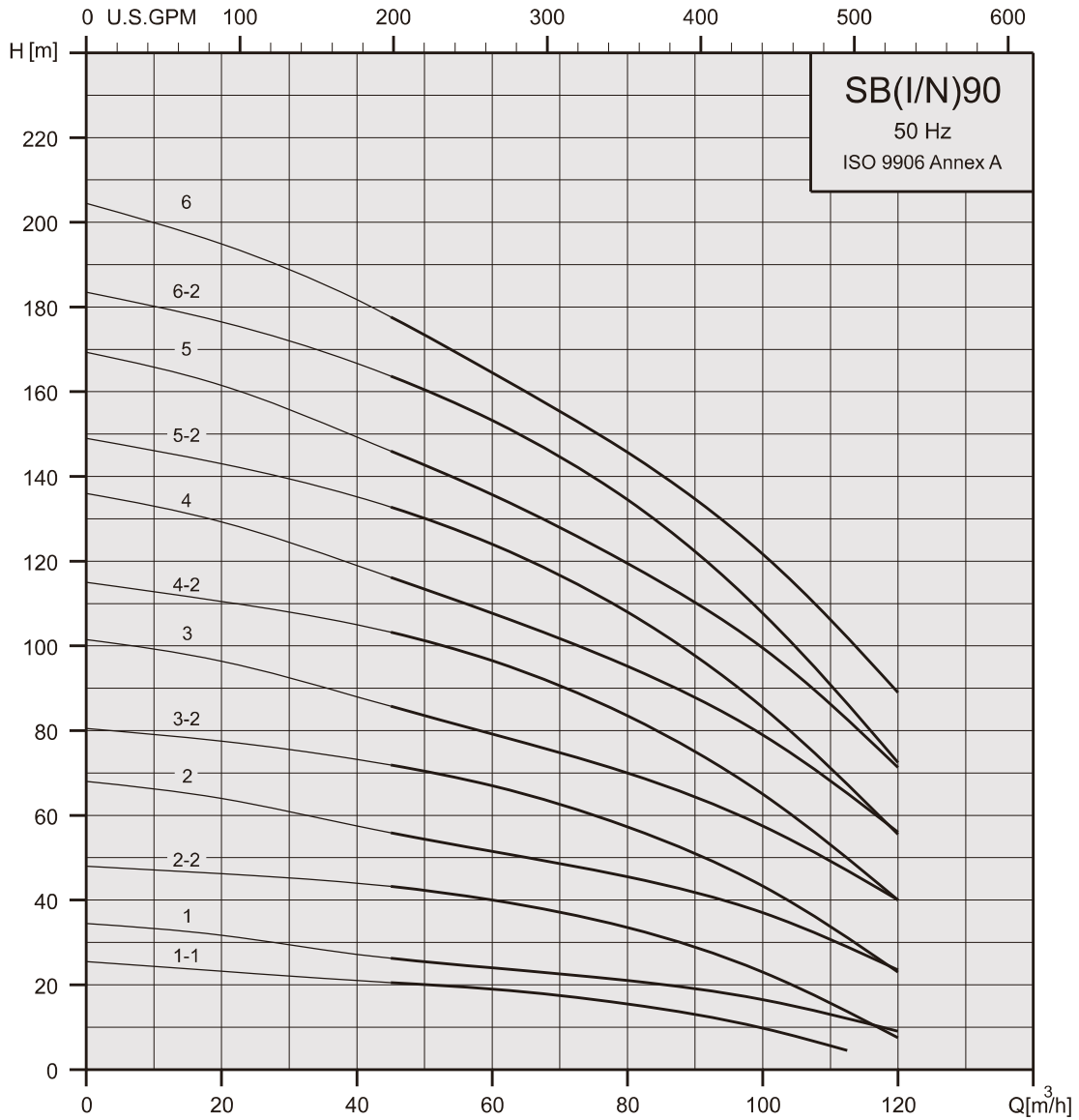

Technical data

Vertical Multistage Centrifugal In-line Pumps

SB(I/N) 90



STAIRS

SB 90

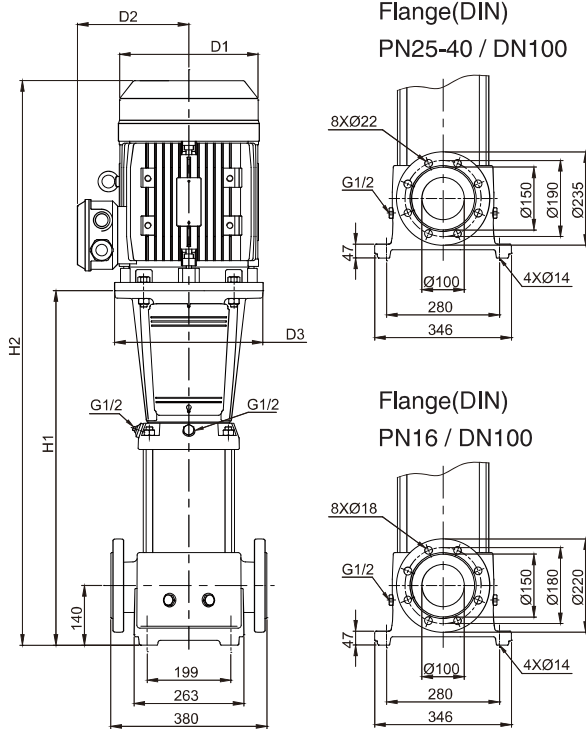

SBI / SBN 90

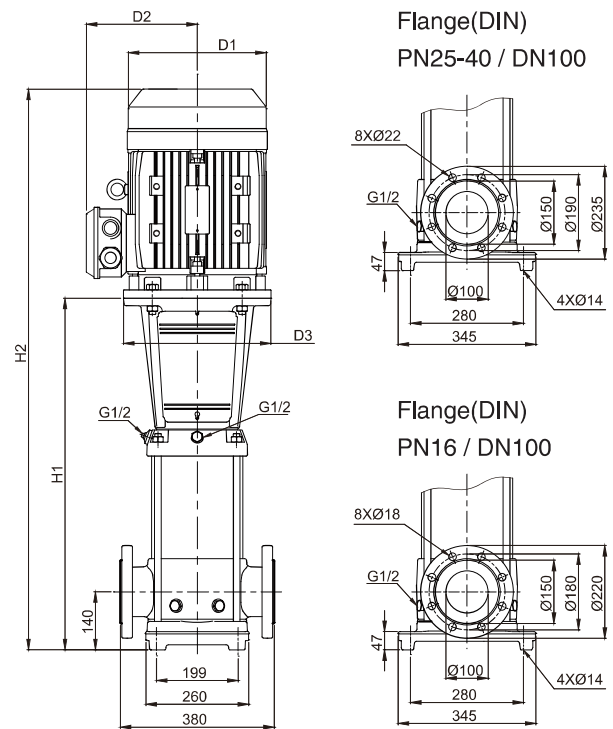

SB 90

50Hz	Motor		Nominal current [A]				Dimension[mm]					Net weight [kg]
	P ₂		3ø		3ø		DIN flange		D1	D2	D3	
Pump type	[kW]	[HP]	△220-240V	Y380-415V	△380-415V	Y660-720V	H1	H2	D1	D2	D3	DIN flange
SB 90-1-1	5.5	7.5	18.7 - 18.0	10.8 - 10.4	10.9 - 10.8	6.3 - 6.2	572	934	235	197	300	115.0
SB 90-1	7.5	10	25.5 - 24.9	14.7 - 14.4	14.9 - 14.8	8.6 - 8.5	572	977	235	197	300	120.9
SB 90-2-2	11	15	38.8 - 39.1	22.4 - 22.6	22.9 - 23.8	13.2 - 13.7	774	1219	269	215	350	163.5
SB 90-2	15	20	49.3 - 46.5	28.5 - 26.9	24.9 - 29.0	16.9 - 16.7	774	1264	269	215	350	174.1
SB 90-3-2	18.5	25	60.2 - 55.4	34.8 - 32.0	35.2 - 33.5	20.3 - 19.3	866	1406	318	241	350	212.2
SB 90-3	22	30	71.3 - 67.5	41.2 - 39.0	41.3 - 39.6	23.8 - 22.8	866	1406	318	241	350	225.0
SB 90-4-2	30	40	—	—	55.4 - 50.7	31.9 - 29.2	958	1618	390	295	400	333.9
SB 90-4	30	40	—	—	55.4 - 50.7	31.9 - 29.2	958	1618	390	295	400	333.9
SB 90-5-2	37	50	—	—	67.7 - 62.0	39.0 - 35.7	1050	1710	390	295	400	356.6
SB 90-5	37	50	—	—	67.7 - 62.0	39.0 - 35.7	1050	1710	390	295	400	356.6
SB 90-6-2	45	60	—	—	82.3 - 75.4	47.4 - 43.4	1142	1832	446	325	450	437.9
SB 90-6	45	60	—	—	82.3 - 75.4	47.4 - 43.4	1142	1832	446	325	450	437.9

SBI ,SBN 90

50Hz	Motor		Nominal current [A]				Dimension[mm]					Net weight [kg]
	P ₂		3ø		3ø		DIN flange		D1	D2	D3	
Pump type	[kW]	[HP]	△220-240V	Y380-415V	△380-415V	Y660-720V	H1	H2	D1	D2	D3	DIN flange
SBI(N) 90-1-1	5.5	7.5	18.7 - 18.0	10.8 - 10.4	10.9 - 10.8	6.3 - 6.2	576	938	235	197	300	111.4
SBI(N) 90-1	7.5	10	25.5 - 24.9	14.7 - 14.4	14.9 - 14.8	8.6 - 8.5	576	981	235	197	300	117.3
SBI(N) 90-2-2	11	15	38.8 - 39.1	22.4 - 22.6	22.9 - 23.8	13.2 - 13.7	778	1223	269	215	350	159.7
SBI(N) 90-2	15	20	49.3 - 46.5	28.5 - 26.9	24.9 - 29.0	16.9 - 16.7	778	1268	269	215	350	170.3
SBI(N) 90-3-2	18.5	25	60.2 - 55.4	34.8 - 32.0	35.2 - 33.5	20.3 - 19.3	870	1410	318	241	350	208.4
SBI(N) 90-3	22	30	71.3 - 67.5	41.2 - 39.0	41.3 - 39.6	23.8 - 22.8	870	1410	318	241	350	221.2
SBI(N) 90-4-2	30	40	—	—	55.4 - 50.7	31.9 - 29.2	962	1622	390	295	400	329.9
SBI(N) 90-4	30	40	—	—	55.4 - 50.7	31.9 - 29.2	962	1622	390	295	400	329.9
SBI(N) 90-5-2	37	50	—	—	67.7 - 62.0	39.0 - 35.7	1054	1714	390	295	400	355.0
SBI(N) 90-5	37	50	—	—	67.7 - 62.0	39.0 - 35.7	1054	1714	390	295	400	355.0
SBI(N) 90-6-2	45	60	—	—	82.3 - 75.4	47.4 - 43.4	1146	1836	446	325	450	436.1
SBI(N) 90-6	45	60	—	—	82.3 - 75.4	47.4 - 43.4	1146	1836	446	325	450	436.1