

Product data

Vertical Multistage Centrifugal In-line Pumps



STAIRS

50Hz

Range	SB, SBI, SBN					
	32	45	64	90	120	150
50Hz						
Nominal flow [m ³ /h]	30	45	64	90	120	150
Flow range [m ³ /h]	15-40	22-58	30-85	45-120	60-160	75-180
Max. pressure [bar]	27.5	33	21.8	20	20.4	18.7
Fluid temperature [°C]	-15 to +120					
Motor power [kW]	1.5-30	3-45	4-45	5.5-45	11-75	11-75
Version						
SB: Cast iron and stainless steel EN 1.4301/AISI 304	•	•	•	•	•	•
SBI: Stainless steel EN 1.4301/AISI 304	•	•	•	•	•	•
SBN: Stainless steel EN 1.4401/AISI 316	•	•	•	•	•	•
Motor						
Mains connection 1- [V/Hz] (Permissible voltage tolerance ± 10%)	0.37-2.2 kW 220-240 V					
Mains connection 3- [V/Hz] (Permissible voltage tolerance ± 10%)	0.37-2.2 kW 220-240 V / 380-415 V 3 - 22 kW 220-240 V / 380-415 V 3 - 22 kW 380-415 V / 660-720 V 30 - 75 kW 380-415 V / 660-720 V					
Insulation class	F					
Enclosure class	IP 55					
Ambient temperature	50 °C					
SB, SBI, SBN Pipe Connection						
Flange	DN 65	DN 80	DN100	DN100	DN125	DN125
SBI, SBN Pipe Connection						
Victaulic-connections	N/A	N/A	N/A	N/A	N/A	N/A
Mechanical Seals						
SiC/SiC	Standard					
Seals						
EPDM	Standard				0.37kW-45kW	
Viton					55kW-75kW	

* Flange standards : Refer to dimensional drawings

Construction

Vertical Multistage Centrifugal In-line Pumps



STAIRS

SB-32,45,64,90

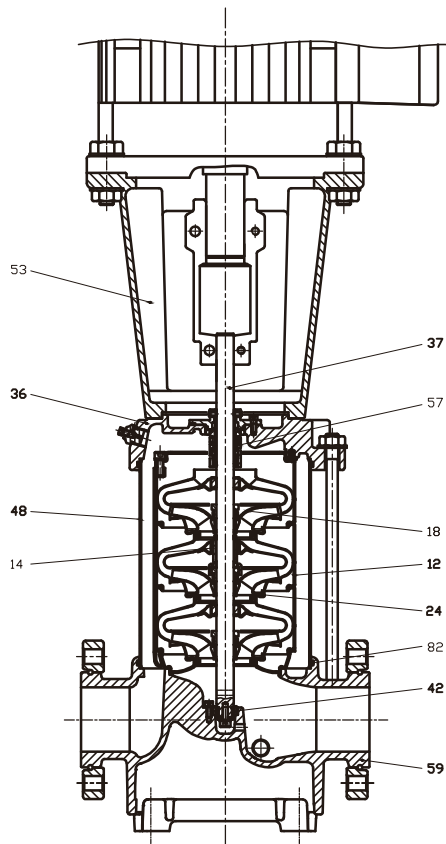

SBI(N)-32,45,64,90

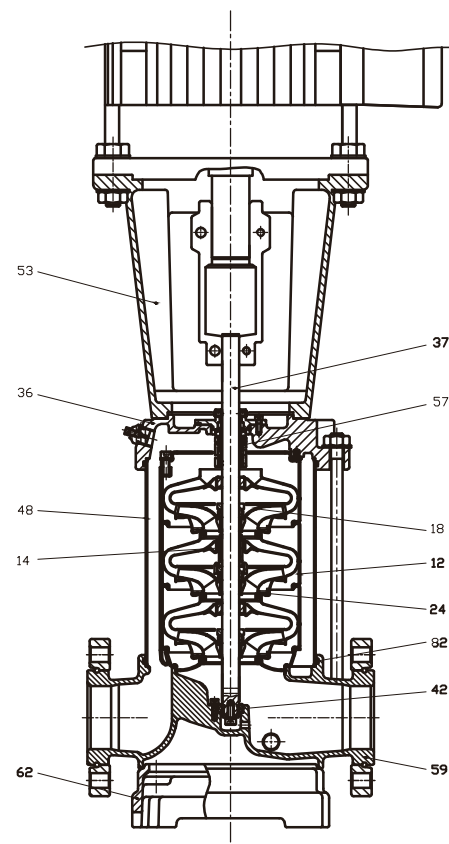

CONSTRUCTION

Pos.	Name	Material	SB 32, 45, 64, 90		SBI 32, 45, 64, 90		SBN 32, 45, 64, 90	
			Standard		Standard		Standard	
			Europe	USA	Europe	USA	Europe	USA
36	Pump head	Cast Iron	EN-GJL-250	ASTM 35B				
		Stainless steel			1.4301	AISI 304	1.4401	AISI 316
53	Motor Bracket	Cast Iron	EN-GJL-250	ASTM 35B	EN-GJL-250	ASTM 35B	EN-GJL-250	ASTM 35B
18	Impeller	Stainless steel	1.4301	AISI 304	1.4301	AISI 304	1.4401	AISI 316
37	Shaft	Stainless steel	1.4057	AISI 431	1.4057	AISI 431	1.4401	AISI 316
48	Outer Sleeve	Stainless steel	1.4301	AISI 304	1.4301	AISI 304	1.4401	AISI 316
82	O-ring for outer sleeve	EPDM						
12	Chamber	Stainless steel	1.4301	AISI 304	1.4301	AISI 304	1.4401	AISI 316
24	Neck ring	Carbon Fiber + POB + PTFE						
59	Base	Cast Iron	EN-GJL-250	ASTM 35B	N/A			
	Base	Stainless steel	N/A		1.4301	AISI 304	1.4401	AISI 316
62	Base plate	Cast Iron	N/A		EN-GJL-250	ASTM 35B	EN-GJL-250	ASTM 35B
57	Mechanical seal	Cartridge type						
14	Bearing ring		Bronze				POB+Graphite+PTFE	
42	Bottom bearing ring	Tungsten carbide/ Tungsten carbide						

Performance Curves

Vertical Multistage Centrifugal In-line Pumps

SB 45



STAIRS

SB, SBI, SBN 45

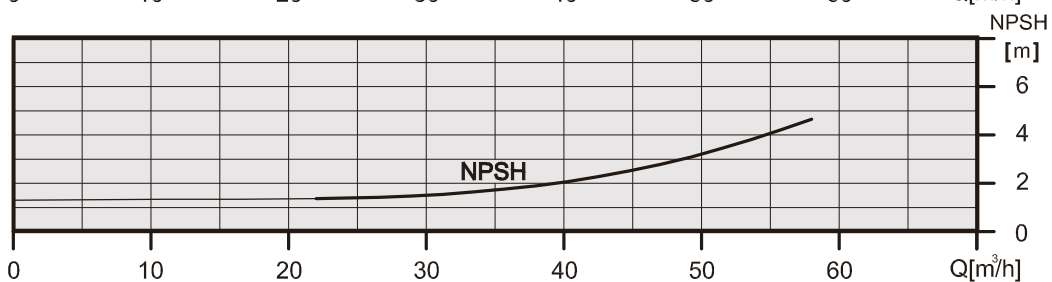
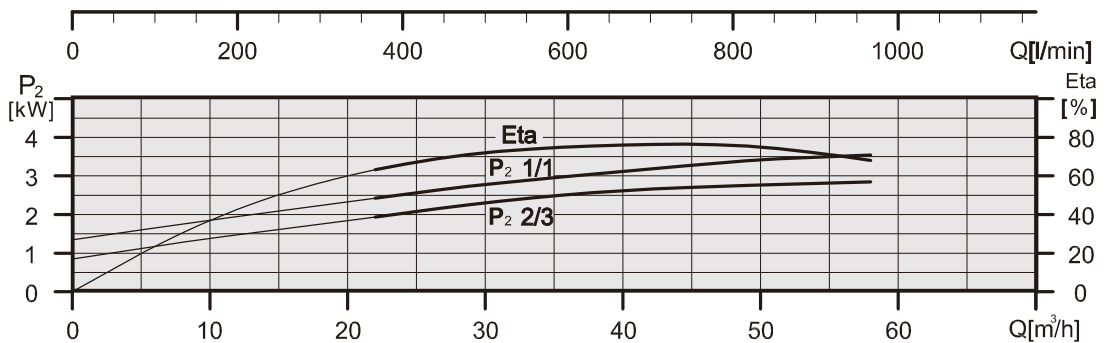
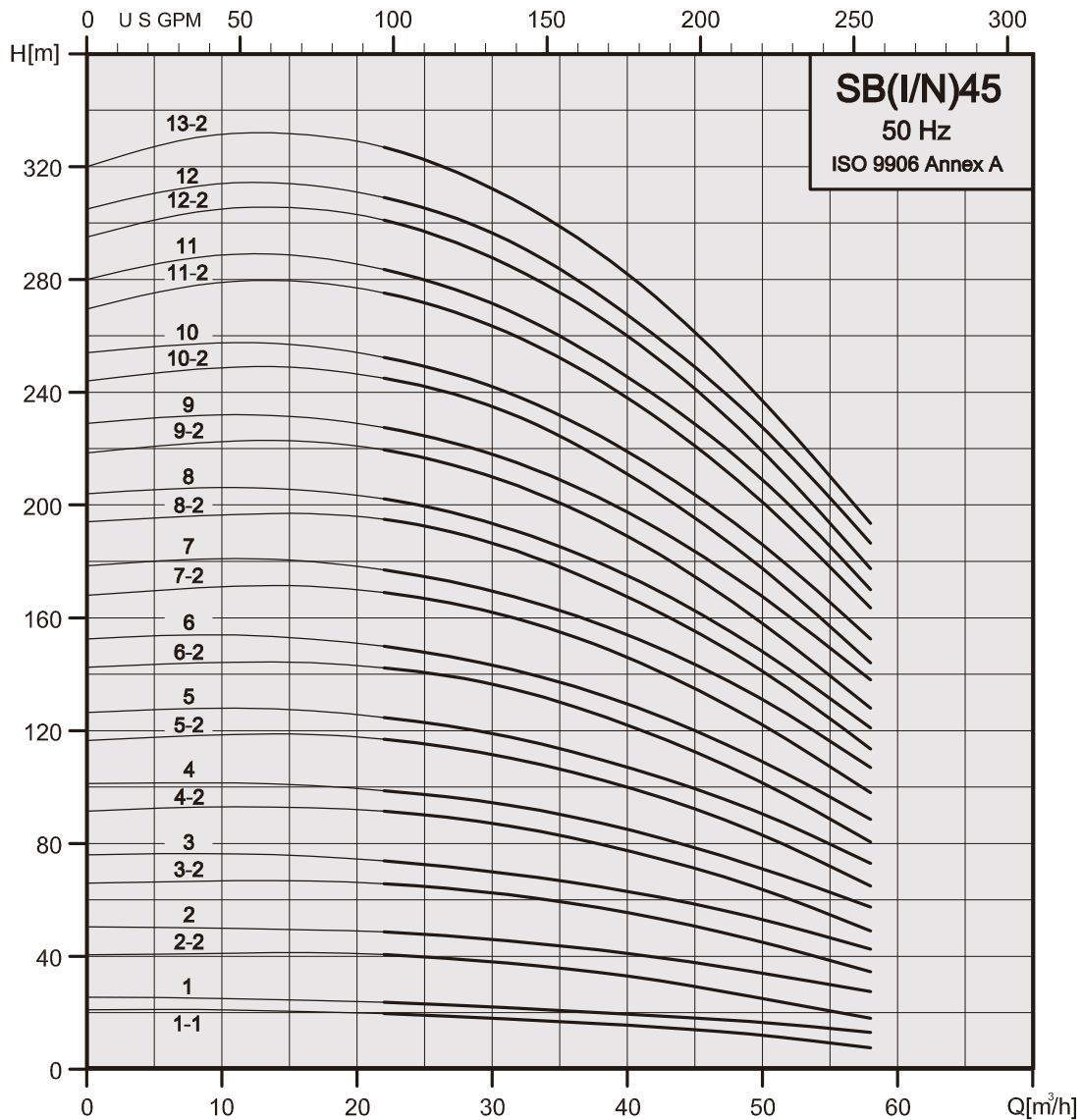



SB 45

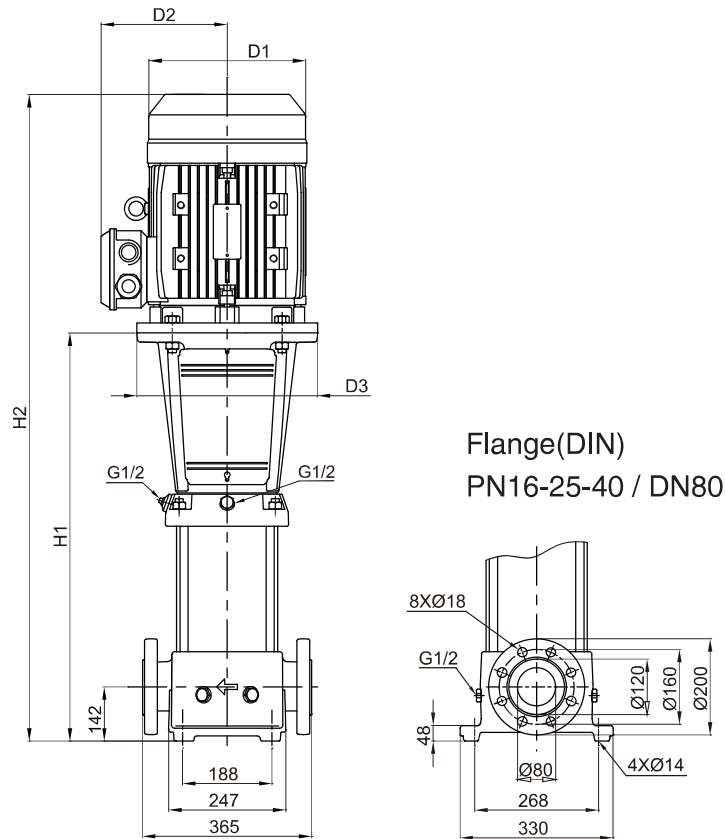

SB 45

50Hz	Motor		Nominal current [A]				Dimension[mm]					Net weight [kg]
	P ₂		3Ø		3Ø		DIN flange		D1	D2	D3	
Pump type	[kW]	[HP]	△220-240V	Y380-415V	△380-415V	Y660-720V	H1	H2				
SB 45-1-1	3	4	11.8 - 12.3	6.8 - 7.1	6.8 - 6.9	3.9 - 4.0	561	877	197	147	280	93.1
SB 45-1	4	5.5	15.1 - 15.2	8.7 - 8.8	8.7 - 8.3	5.0 - 4.8	561	887	220	161	280	97.1
SB 45-2-2	5.5	7.5	18.7 - 18.0	10.8 - 10.4	10.9 - 10.8	6.3 - 6.2	641	1003	235	197	300	117.6
SB 45-2	7.5	10	25.5 - 24.9	14.7 - 14.4	14.9 - 14.8	8.6 - 8.5	641	1046	235	197	300	123.5
SB 45-3-2	11	15	38.8 - 39.1	22.4 - 22.6	22.9 - 23.8	13.2 - 13.7	831	1276	269	215	350	164.5
SB 45-3	11	15	38.8 - 39.1	22.4 - 22.6	22.9 - 23.8	13.2 - 13.7	831	1276	269	215	350	164.5
SB 45-4-2	15	20	49.3 - 46.5	28.5 - 26.9	24.9 - 29.0	16.9 - 16.7	911	1401	269	215	350	178.9
SB 45-4	15	20	49.3 - 46.5	28.5 - 26.9	24.9 - 29.0	16.9 - 16.7	911	1401	269	215	350	178.9
SB 45-5-2	18.5	25	60.2 - 55.4	34.8 - 32.0	35.2 - 33.5	20.3 - 19.3	991	1531	318	241	350	215.6
SB 45-5	18.5	25	60.2 - 55.4	34.8 - 32.0	35.2 - 33.5	20.3 - 19.3	991	1531	318	241	350	215.6
SB 45-6-2	22	30	71.3 - 67.5	41.2 - 39.0	41.3 - 39.6	23.8 - 22.8	1071	1611	318	241	350	231.1
SB 45-6	22	30	71.3 - 67.5	41.2 - 39.0	41.3 - 39.6	23.8 - 22.8	1071	1611	318	241	350	231.1
SB 45-7-2	30	40	—	—	55.4 - 50.7	31.9 - 29.2	1151	1811	390	295	400	359.5
SB 45-7	30	40	—	—	55.4 - 50.7	31.9 - 29.2	1151	1811	390	295	400	359.5
SB 45-8-2	30	40	—	—	55.4 - 50.7	31.9 - 29.2	1231	1891	390	295	400	343.2
SB 45-8	30	40	—	—	55.4 - 50.7	31.9 - 29.2	1231	1891	390	295	400	343.2
SB 45-9-2	30	40	—	—	55.4 - 50.7	31.9 - 29.2	1311	1971	390	295	400	347.0
SB 45-9	37	50	—	—	67.7 - 62.0	39.0 - 35.7	1311	1971	390	295	400	365.0
SB 45-10-2	37	50	—	—	67.7 - 62.0	39.0 - 35.7	1391	2051	390	295	400	368.7
SB 45-10	37	50	—	—	67.7 - 62.0	39.0 - 35.7	1391	2051	390	295	400	368.7
SB 45-11-2	45	60	—	—	82.3 - 75.4	47.4 - 43.4	1471	2161	446	325	450	448.5
SB 45-11	45	60	—	—	82.3 - 75.4	47.4 - 43.4	1471	2161	446	325	450	448.5
SB 45-12-2	45	60	—	—	82.3 - 75.4	47.4 - 43.4	1551	2241	446	325	450	452.5
SB 45-12	45	60	—	—	82.3 - 75.4	47.4 - 43.4	1551	2241	446	325	450	452.5
SB 45-13-2	45	60	—	—	82.3 - 75.4	47.4 - 43.4	1631	2321	446	325	450	455.9