

Product data

Vertical Multistage Centrifugal In-line Pumps



STAIRS

Range	SB, SBI, SBN					
	1	3	5	10	15	20
50Hz						
Nominal flow [m ³ /h]	1.8	3	5.7	10	17	21
Flow range [m ³ /h]	0.7-2.4	1.2-4.5	2.5-8.5	5-13	8.5-23.5	10.5-29
Max. pressure [bar]	21.5	23	24	21.5	23	24.3
Fluid temperature [°C]	-15 to +120					
Motor power [kW]	0.37-2.2	0.37-3	0.37-5.5	0.37-7.5	1.1-15	1.1-18.5
Version						
SB: Cast iron and stainless steel EN 1.4301/AISI 304	•	•	•	•	•	•
SBI: Stainless steel EN 1.4301/AISI 304	•	•	•	•	•	•
SBN: Stainless steel EN 1.4401/AISI 316	•	•	•	•	•	•
Motor						
Mains connection 1- [V/Hz] (Permissible voltage tolerance ± 10%)	0.37-2.2 kW 220-240 V					
Mains connection 3- [V/Hz] (Permissible voltage tolerance ± 10%)	0.37-2.2 kW 220-240 V / 380-415 V 3 - 22 kW 220-240 V / 380-415 V 3 - 22 kW 380-415 V / 660-720 V					
Insulation class	F					
Enclosure class	IP 55					
Ambient temperature	50° C					
SB, SBI, SBN Pipe Connection						
Flange	DN 25 / DN 32	DN 25 / DN 32	DN 25 / DN 32	DN 40	DN 50	DN 50
Oval Flange	RP 1"	RP 1"	RP 1 ¼"	RP 1 ½"	RP 2"	RP 2"
SBI, SBN Pipe Connection						
Victaulic-connections	R 1 ¼	R 1 ¼	R 1 ¼	R 2	R 2	R 2
Mechanical Seals						
SiC/SiC	Standard					
Seals						
EPDM	Standard					
Viton						

* Flange standards : Refer to dimensional drawings

Construction

Vertical Multistage Centrifugal In-line Pumps



STAIRS

SB-1,3,5,10,15,20

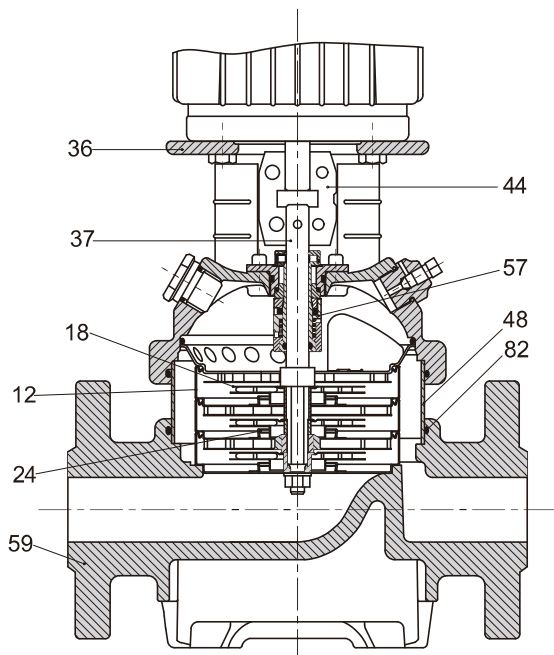

SBI(N)-1,3,5,10,15,20

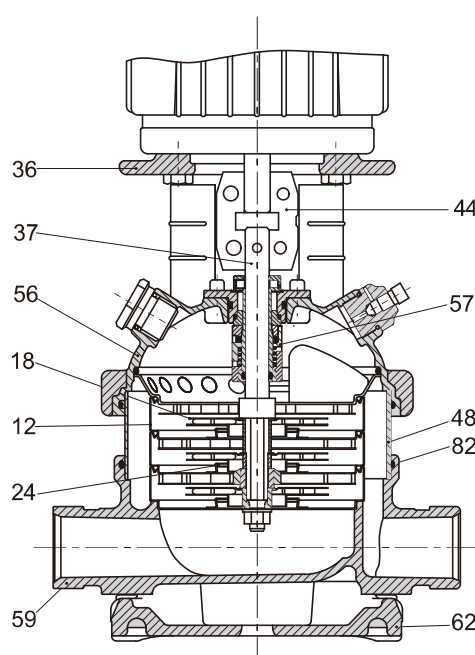

CONSTRUCTION

Pos.	Name	Material	SB 1,3,5,10,15,20		SBI 1,3,5,10,15,20		SBN 1,3,5,10,15,20	
			Standard		Standard		Standard	
			Europe	USA	Europe	USA	Europe	USA
36	Pump head	Cast Iron	EN-GJL-200	ASTM 25B	EN-GJS-450-10	ASTM 65-45-12	EN-GJS-450-10	ASTM 65-45-12
56	Pump head cover	Stainless steel	N/A		1.4301	AISI 304	1.4401	AISI 316
18	Impeller	Stainless steel	1.4301	AISI 304	1.4301	AISI 304	1.4401	AISI 316
37	Shaft	Stainless steel	1.4057	AISI 431	1.4057	AISI 431	1.4401	AISI 316
48	Outer Sleeve	Stainless steel	1.4301	AISI 304	1.4301	AISI 304	1.4401	AISI 316
82	O-ring for outer sleeve	EPDM						
12	Chamber	Stainless steel	1.4301	AISI 304	1.4301	AISI 304	1.4401	AISI 316
24	Neck ring	PTFE						
59	Base	Cast Iron	EN-GJL-200	ASTM 25B	N/A			
	Base	Stainless steel	N/A		1.4301	AISI 304	1.4401	AISI 316
62	Base plate	Cast Iron	N/A		EN-GJL-200	ASTM 25B	EN-GJL-200	ASTM 25B
44	Coupling	Fe-Cu-C	SINT C11	MPIF FC0525	SINT C11	MPIF FC0525	SINT C11	MPIF FC0525
57	Mechanical seal	Cartridge type						



SB, SBI, SBN 15

