



Wilo-Stratos/-D/-Z/-ZD

D Einbau- und Betriebsanleitung

GB Installation and operating instructions

F Notice de montage et de mise en service

NL Inbouw- en bedieningsvoorschriften

Fig. 1a:

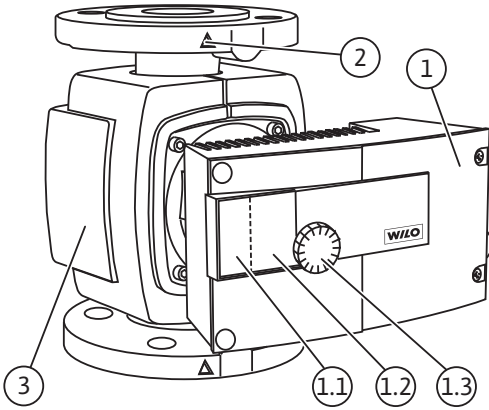

Fig. 1b:

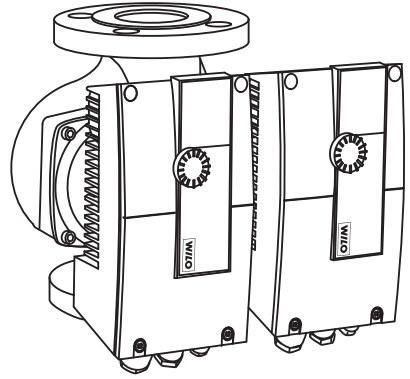

Fig. 2a:

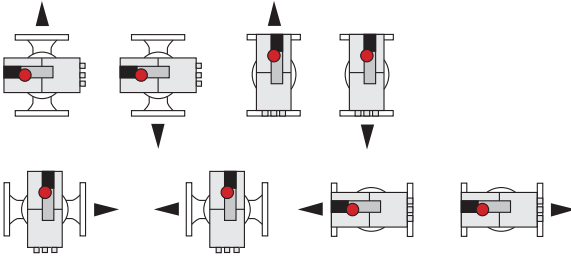

Fig. 2b:

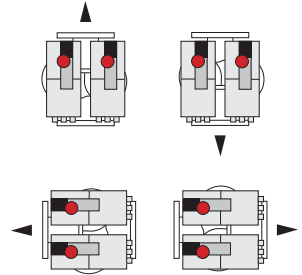

Fig. 3:

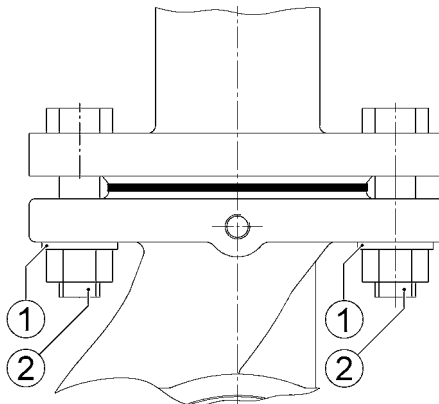

Fig. 4:

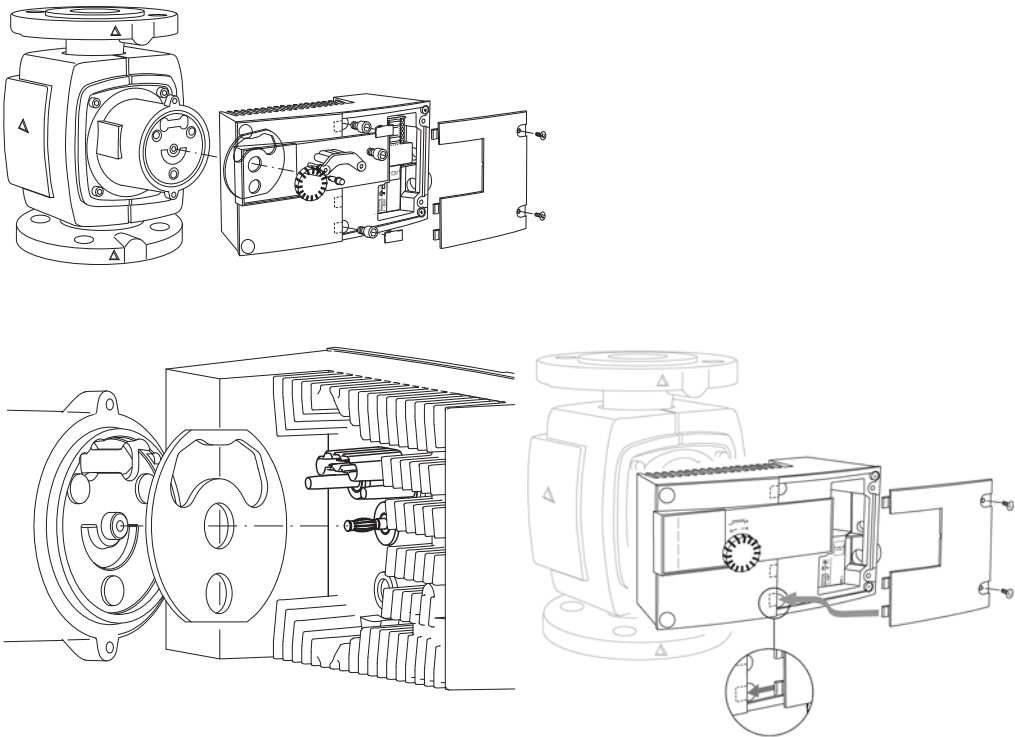

Fig. 5:

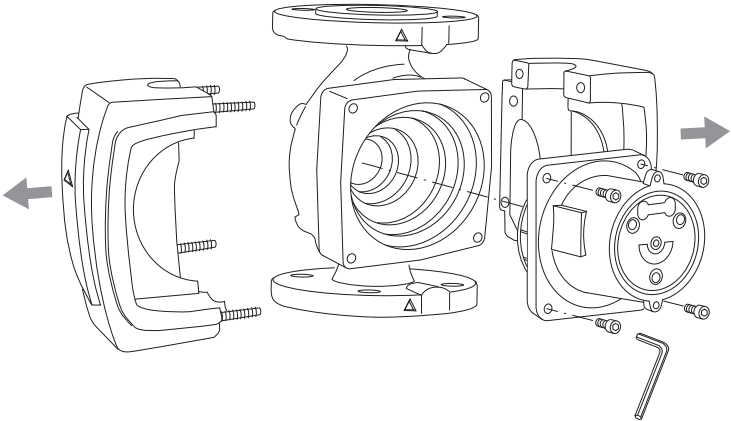

Fig. 6:

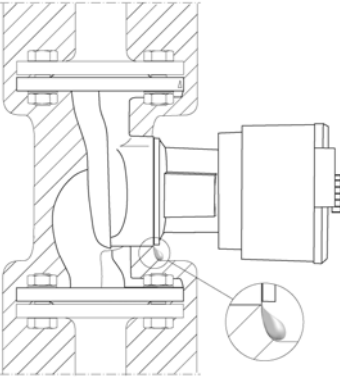

Fig. 7:

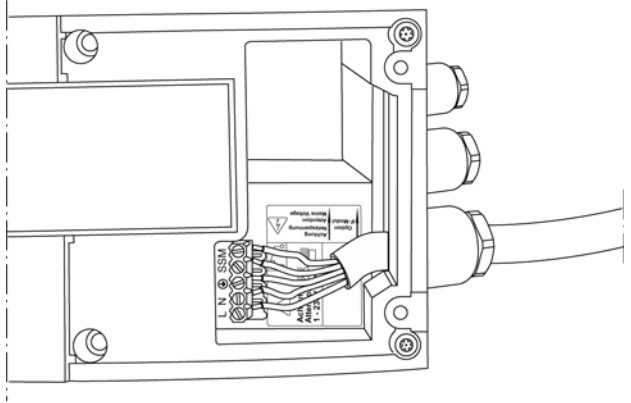

Fig. 8:

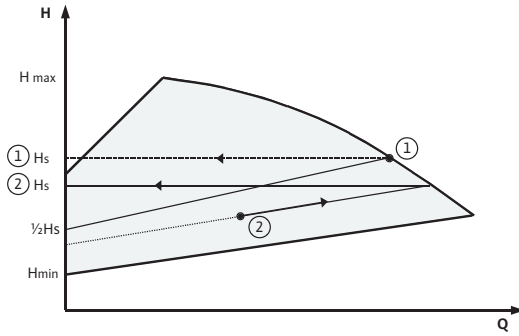

Fig. 9:

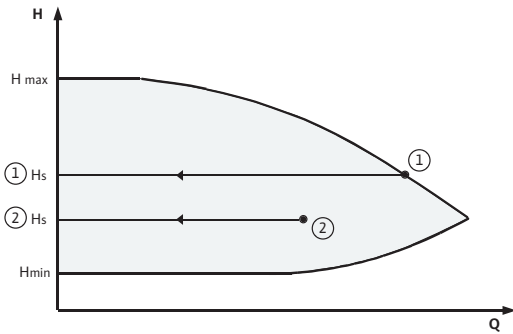

Fig. 10:

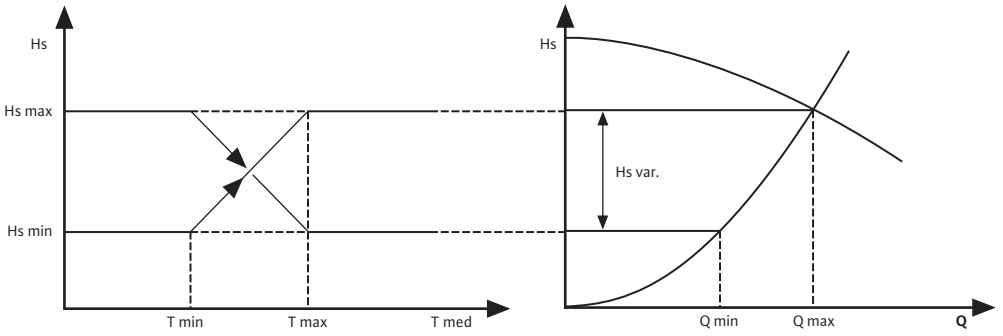
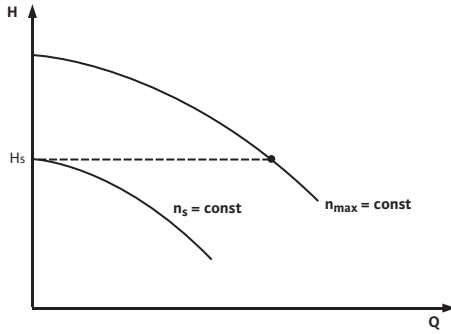

Fig. 11:



D	Einbau- und Betriebsanleitung	6
GB	Installation and Operating Instructions	47
F	Notice de montage et de mise en service	88
NL	Montage- en bedieningsvoorschriften	129

Table of contents	Page
1 General information	47
1.1 About this document	47
2 Safety	47
2.1 Designation of notes in the operating instructions	47
2.2 Personnel qualifications	48
2.3 Danger in the event of failure to observe the safety instructions	48
2.4 Safety instructions for the operator	48
2.5 Safety instructions for inspection and installation work	48
2.6 Unauthorised modification and manufacture of spare parts	48
2.7 Improper use	48
3 Transport and interim storage	48
4 Intended use	49
5 Product details	50
5.1 Type key	50
5.2 Technical data	50
5.3 Scope of delivery	52
5.4 Accessories	52
6 Description and operation	52
6.1 Description of the pump	52
6.2 Operation of the pump	52
6.2.1 Operating modes	53
6.2.2 Differential pressure control modes	54
6.2.3 Further operating modes for saving energy	54
6.2.4 General functions of the pump	55
6.2.5 Twin-head pump operation	55
6.2.6 Definition of the symbols on the LC display	56
7 Installation and electrical connection	58
7.1 Installation	58
7.1.1 Threaded pipe union pump installation type	59
7.1.2 Flange-end pump installation type	59
7.1.3 Removal / installation of the motor impeller unit	60
7.1.4 Removal / installation of the control module	61
7.1.5 Insulation of the pump in cooling/air-conditioning systems	62
7.2 Electrical connection	62
8 Commissioning	64
8.1 Filling and venting	64
8.2 Setting the menu	64
8.2.1 Using the control button (Fig. 1a, pos. 1.3)	64
8.2.2 Switchover of the display	65
8.2.3 Settings in the menu	66
8.3 Selection of the control mode	74
8.4 Setting the pump performance	77
9 Maintenance	78

10	Faults, causes and remedies	78
10.1	Fault signals – Heating/ventilation HV operating mode	79
10.2	Fault signals – Air-conditioning AC operating mode	79
10.3	Warning messages	80
11	Spare parts	85

1 General information

1.1 About this document

These installation and operating instructions are an integral part of the product. They must be kept readily available at the place where the product is stored. Strict adherence to these instructions is a precondition for the proper use and correct operation of the product.

The installation and operating instructions apply to the unit version and the related safety standards at the time of going to press.

2 Safety

These operating instructions contain basic information which must be adhered to during installation and operation. For this reason, these operating instructions must, without fail, be read by the service technician and the responsible operator before installation and commissioning.

Not only the general safety information specified under the main point of safety must be adhered to, but also the special safety instructions with danger symbols inserted under the following main points.

2.1 Designation of notes in the operating instructions

Symbols:

General danger symbol



Danger due to electrical voltage



NOTE:



Signal words:

DANGER!

Acutely dangerous situation.

Non-observance will result in death or serious injuries.

WARNING!

The user can suffer (serious) injuries. 'Warning' implies that (serious) injury to persons is probable if this information is disregarded.

CAUTION!

There is a risk of damaging the pump/unit. 'Caution' implies that damage to the product is likely if the information is disregarded.

NOTE: Useful information on using the product. It also draws attention to possible problems.

2.2 Personnel qualifications

The installation personnel must have the appropriate qualification for this work.

2.3 Danger in the event of failure to observe the safety instructions

Non-observance of the safety instructions can result in risk of injury to persons and damage the pump/unit. Non-observance of the safety instructions can result in the loss of any claims to damages.

In detail, failure to observe the safety instructions may, for example, entail the following risks:

- Failure of important pump/system functions
- Failure of prescribed maintenance and repair procedures
- Danger to persons from electrical, mechanical and bacteriological influences
- Material damage

2.4 Safety instructions for the operator

The existing accident prevention regulations should be observed.

Any hazards from electrical current should be ruled out. Any instructions from local or general directives [e.g. IEC, VDE etc.] or directives of the local electricity supply companies should be observed.

2.5 Safety instructions for inspection and installation work

The operator should ensure that all inspection and installation work is carried out by authorised and qualified personnel who are sufficiently informed from their own detailed study of the operating instructions.

Work on the pump/system may only be carried out when it is at a standstill.

2.6 Unauthorised modification and manufacture of spare parts

Modifications to the pump/unit are only permissible after consultation with the manufacturer. Original spare parts and accessories authorised by the manufacturer ensure safety. The use of other parts can nullify the liability from the results of their usage.

2.7 Improper use

The operating safety of the supplied pump/unit is only guaranteed for conventional use in accordance with Section 4 of the operating instructions. The limit values must on no account fall under or exceed those specified in the catalogue/data sheet.

3 Transport and interim storage

Immediately check the pump and transport packaging for damage in transit upon receipt. Take the necessary steps within the periods defined by the transport company in the event of damage in transit.



CAUTION! Risk of damage to the pump!

Risk of damage due to improper handling during transport and storage.

The pump should be protected against humidity, frost and mechanical damage during transport and interim storage.

4 Intended use

This device is not intended to be operated by persons (including children) with impaired physical, sensory or mental capacities or lack of experience and/or lack of knowledge, except in cases where they are supervised by a person responsible for their safety or where they receive instruction from such a person as to how the device is to be operated.

Children must be kept under supervision in order to ensure that they do not play with the device.

The high-efficiency pumps of the Wilo-Stratos/-D/-Z/-ZD series are used to circulate fluids (no oil or oleiferous fluids, no foodstuffs) in

- Hot-water heating systems
- Cooling and cold water circuits
- Closed industrial circulation systems



WARNING! Danger of damage to health!

The materials of the Wilo-Stratos/-D can cause damage to one's health, since they are not approved for use in secondary hot water circulation systems. Do not use Wilo-Stratos/-D pumps in secondary hot water systems.

The high-efficiency pumps of the Wilo-Stratos-Z/-ZD series are also suitable for use in

- Secondary hot water circulation systems

5 Product details

5.1 Type key

Example: Stratos-D 32/1-12	
Stratos	= high-efficiency pump
	= single-head pump
	-D = twin-head pump
	-Z = single-head pump for secondary hot water circulation systems
	-ZD= twin-head pump for secondary hot water circulation systems (Stratos-ZD not available in Germany)
32	32 = flange connection nominal diameter of 32
	Screwed connection: 25 (Rp 1), 30 (Rp 1¼)
	Flange connection: 32, 40, 50, 65, 80, 100
	Combination flange (PN 6/10):DN 32, 40, 50, 65
1-12	1 = lowest selectable delivery head in [m]
	12 = maximum delivery head in [m] at Q = 0 m ³ /h

5.2 Technical data

Max. flow rate	Depends on the pump type (see catalogue)
Max. delivery head	Depends on the pump type (see catalogue)
Speed	Depends on the pump type (see catalogue)
Mains voltage	1~230 V ±10% according to DIN IEC 60038
Rated current	See name plate
Frequency	50/60 Hz
Insulation class	F
Protection class	IP 44
Power consumption P ₁	See name plate
Nominal diameters	See Section 5.1 Type key
Connection flange	See Section 5.1 Type key
Admissible ambient temperature	-10°C to +40°C
Max. rel. humidity	≤ 95%
Admissible fluids	Heating water (according to VDI 2035/VdTÜV Tch 1466)
Wilo-Stratos/-D/-Z/-ZD	Water/glycol mixtures, max. mixing ratio of 1:1 (the delivery data of the pump should be corrected according to the higher viscosity, depending on the mixing ratio percentage, if glycol is added)
	Ethylene/propylene glycol with corrosion inhibitors
	Commercially available oxygen scavengers ¹⁾
	Commercially available corrosion inhibitors ¹⁾
	Commercially available combination products ¹⁾
	Commercially available cooling brines ¹⁾

5.2 Technical data

Wilo-Stratos-Z	Potable water and water for companies dealing with food in accordance with the 2001 Drinking Water Ordinance
Admissible fluid temperature	Heating, ventilation, air-conditioning applications: -10°C to +110°C Secondary hot water circulation applications: 0°C to +80°C
Max. admissible operating pressure	PN 6/10 ²⁾ PN 16 ³⁾
Sound pressure level	< 54 dB(A)
EMC (electromagnetic compatibility)	General EMC: EN 61800-3
Emitted interference	EN 61000-6-3, previously EN 50081-1 (building standard)
Interference resistance	EN 61000-6-2, previously EN 50082-2 (industrial standard)
Residual current ΔI	$\leq 3,5$ mA (see also Chap. 7.2)

¹⁾ See following warning

²⁾ Standard version

³⁾ Special version or supplementary equipment (additional charge)



CAUTION! Risk of material damage!

Unacceptable fluids may destroy the pump.

- **¹⁾ Observe the specifications of the manufacturer regarding the mixing ratios.**

Add additives to the fluid on the pressure side of the pump.

Minimum inlet pressure (above atmospheric pressure) at the suction port in order to avoid cavitation noises (at fluid temperature T_{Med}):

Nominal diameter	T_{Med}	T_{Med}	T_{Med}
	-10°C...+50°C	+95°C	+110°C
Rp 1	0.3 bar	1.0 bar	1.6 bar
Rp 1¼	0.3 bar	1.0 bar	1.6 bar
DN 32	0.3 bar	1.0 bar	1.6 bar
DN 40 ($H_{max} \leq 8m$)	0.3 bar	1.0 bar	1.6 bar
DN 40	0.5 bar	1.2 bar	1.8 bar
DN 50 ($H_{max} \leq 8m$)	0.3 bar	1.0 bar	1.6 bar
DN 50	0.5 bar	1.2 bar	1.8 bar
DN 65 ($H_{max} \leq 9m$)	0.5 bar	1.2 bar	1.8 bar
DN 65	0.7 bar	1.5 bar	2.3 bar
DN 80	0.7 bar	1.5 bar	2.3 bar
DN 100	0.7 bar	1.5 bar	2.3 bar

The values apply up to 300 m above sea level; allowance for higher positions: 0.01 bar/100 m increase in height.

5.3 Scope of delivery

- Pump, complete
 - Two seals for threaded connection
 - Two-piece thermal insulation shell (single-head pump only, Fig. 1a, pos. 3)
 - Material: EPP, foamed polypropylene
 - Thermal conductivity: 0.04 W/m according to DIN 52612
 - Flammability: B2 class according to DIN 4102, FMVSS 302
- Eight M12 washers (for M12 flange bolts for DN32–DN65 combination flanged version)
- Eight M16 washers (for M16 flange bolts for DN32–DN65 combination flanged version)
- Installation and operating instructions

5.4 Accessories

Accessories must be ordered separately:

- IF-modules
 - IR monitor
 - IR module
 - ClimaForm pump cold water insulation
- See catalogue for detailed list.

6 Description and operation

6.1 Description of the pump

Wilo-Stratos high-efficiency pumps are glandless pumps with integrated differential pressure control and “**Electronic Commutated Motor**” (ECM) technology. They can be installed as **single-head** (Fig. 1a) or **twin-head pumps** (Fig. 1b).

- 1 Control module
 - 1.1 Infrared interface
 - 1.2 LC display
 - 1.3 Red button
- 2 Pump housing
- 3 Thermal insulation

6.2 Operation of the pump

If the pump has an axial design, there is a **control module** (Fig. 1a, Pos.1) on the motor housing, which regulates the differential pressure of the pump to an adjustable setpoint within the control range. The differential pressure is based on different criteria, depending on the control mode. In all control modes, however, the pump constantly adapts to the changing output requirements of the system, which arise in particular when using thermostatic valves, zone valves or mixers.

The basic advantages of the electronic control are:

- Energy savings and hence reduction of the operating costs
- Reduction of flow noises
- Reduction of the number of differential pressure valves required

High-efficiency pumps of the Wilo-Stratos-Z/-ZD series are adapted specifically to the operating conditions in secondary hot water circulation systems due to the materials selected and their design. All materials which come into contact with the fluid are approved in accordance with KTW/WRC (WRAS). Any national regulations and directives should also be observed when using the Wilo-Stratos-ZD series (pump housing of cast iron) in secondary hot water circulation systems.

6.2.1 Operating modes

The Stratos series can be operated in the operating modes “Heating” or “Cooling/air-conditioning”. The two operating modes are distinguished from one another in their tolerance for faults in the handling of fault signals that occur.

“Heating” operating mode:

Faults are handled in a tolerant fashion (as is normally the case), e.g. depending on the type of fault, the pump does not signal a fault until the same fault has occurred repeatedly within a particular time period. Error matrix: **“HV”**

“Cooling/air-conditioning” operating mode:

For all applications for which each fault (in the pump or the system) must be recognised quickly (e.g. air-conditioning applications).

Each fault, with the exception of the fault E10 (blocking), will be signalled at once (< 2 sec.). In the event of a blocking (E10), various restart attempts will be carried out, which means that in such cases no fault message will occur until after a maximum of 40 sec.

Error matrix: **“AC”**

Both operating modes distinguish between faults and warnings. In the event of a malfunction, the motor is switched off, the error code on the monitor is displayed and the malfunction is signalled with the red LED.

Malfunctions always lead to activation of the SSM.

In the case of twin-head pump management (twin-head pump or 2x single-head pumps), the standby pump starts within the time period specified below following the appearance of the fault.

Stratos, Stratos-D, Stratos-Z, Stratos-ZD	Starting time
25/1-6, 30/1-6, 25/1-8, 30/1-8, 32/1-8, 40/1-4	approx. 9 sec
30/1-12, 32/1-12, 40/1-8, 50/1-8	approx. 4 sec
40/1-12, 50/1-9, 50/1-12	approx. 4 sec
65/1-12	approx. 3 sec
80/1-12, 100/1-12	approx. 7 sec

6.2.2 Differential pressure control modes

- **$\Delta p-v$:** The electronics change the differential pressure setpoint to be maintained by the pump linearly between $\frac{1}{2}H_S$ and H_S . The differential pressure setpoint H falls or increases together with the flow rate (Fig. 8); basic works setting.
- **$\Delta p-c$:** The electronics keep the differential pressure generated by the pump constantly at the set differential pressure setpoint H_S up to the maximum pump curve over the admissible volume flow range (Fig. 9).
- **$\Delta p-T$:** The electronics change the differential pressure setpoint to be maintained by the pump, depending on the measured fluid temperature. This control mode can only be set with the IR monitor/IR module or via PLR/LON/CAN. Two settings are possible (Fig. 10):
 - Control with positive gradient: as the fluid temperature rises, the differential pressure setpoint rises linearly between H_{Smin} and H_{Smax} (setting: $H_{Smax} > H_{Smin}$).
 - Control with negative gradient: as the fluid temperature rises, the differential pressure setpoint falls linearly between H_{Smin} and H_{Smax} (setting: $H_{Smax} < H_{Smin}$).

6.2.3 Further operating modes for saving energy

- **Manual control mode:** The speed of the pump is maintained at a constant speed between n_{min} and n_{max} (Fig. 11). Manual control mode deactivates the differential pressure control at the module.
- In **“auto” operating mode** (basic works setting), the pump is able to identify the minimum heating requirements of the system by gradually lowering the fluid temperature and then switching to **“Autopilot” setback mode**. Control mode is automatically activated whenever the heating requirements increase. This setting ensures that the power consumption of the pump is reduced to a minimum, and is the ideal setting in most cases.



CAUTION! Risk of material damage!

“Autopilot” setback mode may only be enabled when the system is hydraulically balanced. Inadequately supplied system parts may otherwise freeze in the event of frost.

6.2.4 General functions of the pump

- The pump is equipped with an electronic **overload protection** function which switches off the pump in the event of overloading.
- The control module is equipped with a non-volatile memory for **saving data**. All settings and data are retained if the mains supply is interrupted for any period of time. The pump continues to run with the control values set prior to the interruption of the mains supply when the power returns.
- **Pump kick:** Any pumps switched off via the menu (ON/OFF), a bus communication, the infrared interface, the Ext.Off control input or 0-10V start running for a short time every 24 hours to prevent blockages in the event of long periods of standstill. The mains voltage must not be interrupted for this function.
If the mains is intended to be switched off for a long period of time, the pump kick must be assumed by the heating/boiler control system by briefly switching on the mains voltage. For this purpose, the pump must be switched on by the control system prior to the interruption to the mains supply (display → motor/module symbol lit up).

6.2.5 Twin-head pump operation









- Twin-head pumps or two single-head pumps (installed in parallel) can be retro-fitted with an integrated dual pump management.
- **IF-modules Stratos:** For communication between the pumps, an IF module is installed in the control module of each of the pumps connected via the DP interface.
- This dual pump management has the following functions:
- **Master/Slave:** Both pumps are controlled by the master. All settings are made at the master.
- **Main/standby operation:**
Each of the two pumps generates the specified flow rate. The other pump is on stand-by in case of faults or runs after change-over of the pump. Only one pump runs at a time.
- **Efficiency-optimised peak load operation:** In the partial load area, the hydraulic power is initially generated by one of the pumps. The second pump is then switched on to optimise efficiency if the total power consumption P_1 of both pumps is lower than the power consumption P_1 of one pump. Both pumps are then synchronously regulated up to the maximum speed if necessary. Additional energy savings are achieved by this operating mode, compared to conventional peak load operation (load dependent activation and deactivation). Parallel operation of two single-head pumps is only possible with pumps for which there is an equivalent twin-head pump type.
- If one of the pumps has a **breakdown/fault**, the other pump runs as single-head pump in the operating modes specified by the master.
- If **communication is interrupted:** the slave runs in the operating modes specified last by the master.





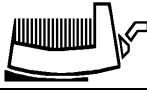



- **Pump alteration:** If only one pump is running (in main/standby, peak load or set-back mode), the pump is changed after every 24 hours of effective running time. Both pumps are running at the time of the pump alteration in order to ensure that operation is not interrupted.



NOTE: Both pumps will always be running if both the manual control mode and the synchronous mode are active at the same time. No pump alteration takes place. No pump alteration takes place during the active night reduction after 24 h of effective running time.

6.2.6 Definition of the symbols on the LC display

Symbol	Definition
auto 	Control mode; automatic switchover to setback mode is enabled. Set-back mode is activated at the minimum heating requirement.
auto 	Pump runs in setback mode (night reduction) at min. speed.
(no symbol)	Automatic switchover to setback mode disabled, i.e. pump runs solely in control mode.
	Setback mode activated via PLR/LON/CAN interface or Ext.Min, regardless of the system temperature.
	Pump runs in warm-up mode at maximum speed. The setting can be activated only via PLR/LON/CAN.
	Pump is switched on.
	Pump is switched off.
H 5,0 m	Differential pressure setpoint is set to H = 5.0 m.
	Δp -v control mode, regulation to variable differential pressure setpoint (Fig. 8)
	Δp -c control mode, regulation to constant differential pressure setpoint (Fig. 9)
	Manual control mode deactivates regulation in the module. The speed of the pump is maintained at a constant value. The speed is adjusted using the red button (Fig. 11) or via PLR/LON/CAN.
26,0 ^{RPM} _{x100}	The pump is set to a constant speed (2,600 rpm in this case) (manual control mode).

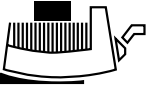
Symbol	Definition
10V	In the manual control mode, the speed and the nominal delivery head of the Δp -c or Δp -v operating mode of the pump can be set via the 0-10V input of the Stratos IF-modules Ext.Off, Ext.Min and SBM. In this case, the red button cannot be used for setpoint entries.
	Δp -T control mode, regulation to temperature-related differential pressure setpoint (Fig. 10) The current setpoint H_5 is displayed. This control mode can only be activated via the IR-Monitor/IR-module or via PLR/LON/CAN.
	All settings at the module apart from fault acknowledgement are disabled. They are disabled by the IR-Monitor/IR-module. Settings can only be made and enabled again with the IR-Monitor/IR-module.
	The pump is operated via a serial data interface. The "On/Off" function is not activated at the module. Only   , the display position and fault acknowledgement still have to be set on the module. Operation at the interface can be interrupted temporarily with the IR-Monitor/IR-module (for inspection or for reading out data).
SL	The pump runs as slave pump. No changes can be made on the display.
	The twin-head pump runs in efficiency-optimised peak load operation mode (master + slave).
	The twin-head pump runs in main/standby mode (master or slave).
	Displayed for pump with IF module LON in order to send a service message to the building control centre.
 ft	The pump is set in the "US units" mode.
HV	Fault-tolerant error matrix activated. Heating operating mode (in case of malfunction, see Chap. 10)
AC	Fault-tolerant error matrix deactivated. Air-conditioning operating mode (in case of malfunction, see Chap. 10)

Menu structure: There are three menu levels. The levels beneath the display of the basic settings are always accessed from 1 level by pressing the control button for different lengths of time.

Level 1 – Status display (display of the operating state)

Level 2 – Operation menu (setting the basic functions):

- Pressing the control button longer than 1 s

Level 3 – Options menu (additional settings):

- Pressing the control button longer than 6 s



NOTE: After 30 s without any new entry being made, the display jumps back to Level 1 (display of the operating state). Temporary, non-acknowledged modifications are discarded.

7 Installation and electrical connection

The installation and electrical connection should be performed only by qualified personnel in compliance with local regulations.



WARNING! Risk of personal injury!

The existing accident prevention regulations should be observed.



Warning! Risk of electric shock!

Any hazards from electrical current should be ruled out.

Any instructions from local or general directives [e.g. IEC, VDE etc.] or directives of the local electricity supply companies should be observed.

7.1 Installation

- Installation within a building: install the pump in a dry, well ventilated and frost-resistant room.
- Installation outside a building (outdoor installation):
 - Install the pump in a shaft (e.g. light well, annular shaft) with cover or in a cupboard/housing as weather protection.
 - Avoid exposure of the pump to direct sunlight.
 - Protect the pump against rain. Dripping water from above is permitted, provided the electrical connection is established in accordance with the installation and operating instructions and the terminal box is closed properly.



CAUTION! Risk of material damage!

Ensure sufficient ventilation/heating if the ambient temperature exceeds/falls below the permitted limit values.

- Carry out all welding and soldering work prior to the installation of the pump.



CAUTION! Risk of material damage!

Dirt from the pipe system can destroy the pump during operation. Flush the pipe system prior to the installation of the pump.

- Provide shut-off valves in front of and behind the pump.
- Fasten the pipelines to the floor, ceiling or wall using appropriate devices so that the pump does not bear the weight of the pipelines.
- Remove the two half shells of the thermal insulation (Fig. 5, pos. 1) before installing the single-head pump.
- The safety supply must branch off on the pressure side of the pump if it is installed in the flow pipe of open systems.

- To be observed during the installation:
 - Make sure it is possible to install the pump with the correct flow direction (see Fig. 2a/2b). Observe the direction triangle on the pump housing (Fig. 1a; Pos. 2).
 - Make sure it is possible to install the pump in an admissible installation position (see Fig. 2a/2b). Turn the motor including the control module if necessary, see Section 7.1.3.

7.1.1 Threaded pipe union pump installation type

- Install appropriate pipe unions before installing the pump.
- Use the supplied flat gaskets between the suction/pressure ports and pipe unions when installing the pump.
- Screw union nuts onto the threads of the suction/pressure ports and tighten them using a monkey wrench or pipe wrench.



CAUTION! Risk of material damage!

Do not hold the pump by the motor/module when tightening the screwed connections. Apply the wrench surfaces to the suction/pressure port instead.

Pump type	Wrench surface [mm]	Wrench surface [mm]
	Suction port	Pressure port
Stratos 25/1-6(8)	36	36
Stratos 30/1-6(8)	41	46
Stratos 30/1-12	-	-

- Check the pipe unions for leaks.
- Single-head pump: press the two half shells of the thermal insulation together around the pump housing.

7.1.2 Flange-end pump installation type

Installation of pumps with PN6/10 combination flange (flange-end pumps up to DN 65 inclusive)



WARNING! Danger of injury!

The flange connection may crack when connecting two combination flanges. There is a danger of injury due to metal parts flying about and hot fluid escaping. Never connect two combination flanges.

	PN6 nominal pressure	PN10/16 nominal pressure
Screw diameter	M12	M16
Tensile strength class	4.6 or higher	4.6 or higher
Permitted tightening torque	40 Nm	95 Nm
Min. screw length with		
• DN32/DN40	55 mm	60 mm
• DN50/DN65	60 mm	65 mm

	PN6 nominal pressure	PN10/16 nominal pressure
Screw diameter	M16	M16
Tensile strength class	4.6 or higher	4.6 or higher
Permitted tightening torque	95 Nm	95 Nm
Min. screw length with		
• DN80	60 mm	65 mm
• DN100	70 mm	70 mm



CAUTION! Risk of material damage!

Leaks in the flange connection can be caused by using retaining elements (e.g. lock washers), which is the reason why they are not permitted. The supplied washers (Fig. 3, Pos. 1) must be used between the screw/nut head and the combination flange.

Installation of pumps with PN6/10 combination flange (flange-end pumps up to DN 65) and DN 80/DN 100 flange-end pumps.



CAUTION! Risk of material damage!

Use screws of sufficient length. The screw thread must protrude at least one thread turn out of the screw nut (Fig. 3, pos. 2).

- Install appropriate flat gaskets between pump and counter flanges.
- Tighten the flange bolts cross-wise in two steps with the prescribed starting torque (see Table 7.1.2).
 - Step 1: 0.5 x permitted tightening torque
 - Step 2: 1.0 x permitted tightening torque
- Check the flange connections for leaks.
- Single-head pump: press the two half shells of the thermal insulation together around the pump housing.

7.1.3 Removal / installation of the motor impeller unit

- Unscrew four M6 internal hexagon screws (size 5) to disconnect the motor. Possible tools (Fig. 5, pos. 2):
 - Angled hexagonal recess screwdriver
 - Ball-head hexagonal recess screwdriver
 - ¼ inch ratchet wrench with appropriate bit

- The entire motor does not have to be pulled out of the pump housing if only the control module is to be brought into a different position. The motor can be turned into the desired position while inserted in the pump housing if there is sufficient space.



CAUTION! Risk of material damage!

Do not damage the O-ring between the motor head and pump housing in the process. The O-ring must lie unturned in the chamfer of the endshield facing the impeller.



WARNING! Danger of personal injury!



CAUTION! Risk of material damage!

The shaft is connected inseparably to the impeller, the endshield and the rotor. This unit is secured against being accidentally pulled out of the motor. A considerable risk potential is posed, by the sudden attraction of iron/steel objects, interference to electric devices (danger to persons with pacemakers) or destruction of magnetic cards, for example, if the rotor together with its strong magnets is not inserted in the motor housing.

- The control module can be disconnected from the motor by undoing two screws if the screws on the motor flange are unable to be accessed (see Section 7.1.4).

7.1.4 Removal / installation of the control module

- The control module is disconnected from the motor by undoing two screws (Fig. 4):
 - Undo the terminal box cover screws (pos. 1).
 - Remove the terminal box cover (pos. 2).
 - Remove the sealing plugs with a small screwdriver, avoiding damage to the plugs (pos. 3).
The sealing plugs may not be available, depending on the pump type.
 - Undo the M5 internal hexagon screws (size 4) (pos. 4).
 - Pull the control module off the motor (pos. 5).
 - Install the module in the reverse order. Do not forget to install the flat gasket (pos. 6) between the motor housing and control module.



Warning! Danger of electric shock!

Do not stick any sharp objects (nails, screwdrivers, wire) in the contacts on the motor. Dangerous voltages can arise at the motor contacts in dynamic operation of the pump (rotor drive).

7.1.5 Insulation of the pump in cooling/air-conditioning systems

- The thermal insulation shells (Fig. 5, pos. 1) included in the scope of delivery may only be used in heating/secondary hot water circulation applications at fluid temperatures of +20°C or higher, since these thermal insulation shells do not enclose the pump housing in a diffusion-proof manner.
- Use the diffusion-proof Wilo-ClimaForm low-temperature insulation shell in cooling and air-conditioning systems.



CAUTION! Risk of material damage!



If the diffusion-proof insulation is created by the customer, the pump housing may be insulated towards the motor only up to the motorflange, so that the condensate drain openings remain open and allow the condensate accumulating in the motor to flow out without obstruction (Fig. 6).

7.2 Electrical connection



WARNING! Danger of electric shock

The electrical connection should be established by an electrician approved by the local electricity supply company in compliance with the applicable local regulations [e.g. VDE regulations].

- The current type and voltage of the mains connection must correspond to the specifications on the name plate.
- The electrical connection is established via a fixed mains connection line (minimum cross-section of 3 x 1.5 mm²) provided with a plug and socket connector or an all-pole switch with a minimum contact opening width of 3 mm.
- The following minimum requirements are to be met if a shutdown takes place by means of an onsite network relay: nominal current ≥ 10 A, nominal voltage 250 VAC.
- Fuse protection: 10/16 A, slow-blow or automatic cut-outs with C characteristic
 - **Twin-head pumps:** provide a separate mains connection line and a separate fuse on the mains side for both motors of the twin-head pump.
- It is not necessary for a motor protection switch to be installed by the customer. If such a switch is already available in the installation, it should be by-passed or set to the maximum possible current value.
- The pump can be secured with a residual current circuit-breaker.
Designation: RCD -  or 
Take the number of connected pumps and their rated motor currents into account for the calibration of the residual current circuit-breaker.
- Leakage current per pump $I_{\text{eff}} \leq 3,5$ mA (as per EN 60335)
- A heat-resistant connecting cable must be used when using the pump in systems with water temperatures of above 90 °C.
- Under no circumstances may any connecting cables touch the pipeline or the pump or motor housing.
- To ensure drip water protection and strain relief of the cable connections, use cables with an appropriate outer diameter (see Table 7.2) and screw the cable

glands tight. Furthermore any cables nearby screwed connections for outlet loops should be bent in order to divert any accumulating drip water. Close any unassigned cable glands with the existing sealing discs and screw them tight.

• **Assignment of the cable connections:**

The following table shows which combinations of electric circuits the individual cable glands can be assigned in a cable. DIN EN 60204-1 (VDE 0113, Bl.1) should be observed:

- Section 14.1.3 in a nutshell: conductors of different electric circuits may belong to the same multi-conductor cable if the highest voltage which may occur in the cable is insulated sufficiently.
- Section 4.4.2 in a nutshell: signal lines with low levels should be separated from power lines if there is a potential risk of functional interference due to EMC.

		PG 13,5PG	PG 9PG	PG 7PG
	Cable cross-section	8...10 mm	6...8 mm	5...7 mm
1.*	Function	SSM mains line		DP management
	Cable type	5 x 1.5 mm ²		Two-wire cable (l ≤ 2.5 m)
2.	Function	Mains line	SSM	DP management
	Cable type	3 x 1.5 mm ² 3 x 2.5 mm ²	Two-wire cable	Two-wire cable (l ≤ 2.5 m)
3.	Function	Mains line	SSM/0...10V/Ext.Off or SSM/0...10V/Ext.Min or SSM/SBM/0...10V or SSM/SBM/Ext.Off	DP management
	Cable type	3 x 1.5 mm ² 3 x 2.5 mm ²	Multi-wire control cable, number of wires according to number of control circuits, shielded if necessary	Two-wire cable (l ≤ 2.5 m)
4.	Function	Mains line	PLR/LON/CAN	DP management
	Cable type	3 x 1.5 mm ² 3 x 2.5 mm ²	Bus cable	Two-wire cable (l ≤ 2.5 m)
5.	Function	Mains line	LON/CAN	LON/CAN
	Cable type	3 x 1.5 mm ² 3 x 2.5 mm ²	Bus cable	Bus cable

Table 7.2

**WARNING! Danger of electric shock!**

If the mains line and the SSM are fed in a 5 core cable, the SSM must not be monitored with safety extra-low voltage.

**CAUTION! Risk of material damage!**

Disconnect all poles of the pump in the control module from the mains supply when conducting insulation tests with a high-voltage generator. Insulate the bare cable ends according to the voltage of the high-voltage generator.

- Earth the pump/system according to regulations.
- **L, N, ** : line supply voltage: 1~230 VAC, 50/60 Hz, DIN IEC 60038, alternatively a mains connection between two phases of a three-phase current with 3~230 VAC, 50/60 Hz is possible.
- **SSM:** an integrated collective fault signal is applied at the SSM terminals as potential-free normally closed contact. Contact load:
 - Minimum admissible values: 12 V DC, 10 mA
 - Maximum admissible values: 250 VAC, 1 A
- **Switching frequency:**
 - Switch-on/off procedures via mains voltage $\leq 20 / 24$ h
 - Switch-on/off procedures via Ext. Aus, 0-10 V or digital, serial interface ≤ 20 /h



NOTE: The integrated dual pump management will not work if one of the motors of a twin-head pump is disconnected.

8 Commissioning

8.1 Filling and venting

Fill and vent the system correctly. The pump rotor chamber is automatically vented already after a short operating time. Brief dry running will not damage the pump.

**WARNING! Danger of injury!**

There is a risk of burns if the pump is touched! The entire pump may become very hot, depending on the operating state of the pump or system (fluid temperature). The temperature at the cooling radiator may rise up to 70 °C within the permitted operating conditions.

8.2 Setting the menu

8.2.1 Using the control button (Fig. 1a, pos. 1.3)

- From the basic setting, the setting menus are selected one after another by pressing the button (press longer than 1 second for the first menu). The current symbol flashes. The parameters can be moved backwards or forwards on the display by turning the button clockwise or anti-clockwise. The newly set symbol

flashes. The new setting is applied and the next setting option is activated by pressing the button.

- The setpoint (differential pressure or speed) is changed in the basic setting by turning the control button. The new value flashes. The new setpoint is saved by pressing the button.
- The old value is retained and the basic setting is displayed again if the new setting is not confirmed within 30 seconds.

8.2.2 Switchover of the display

- It can be set whether the display is to be turned by 90° for the respective arrangement of the control module, depending on whether it is installed in horizontal or vertical position. The positional setting can be made in menu item 3. The display position specified by the basic setting flashes with "ON" (for horizontal installation position). The display can be switched over by turning the setting knob. "ON" flashes for the vertical installation position. The setting is confirmed by pressing the setting knob.

Switchover of the display

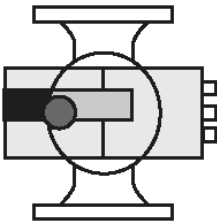
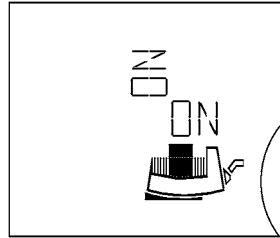
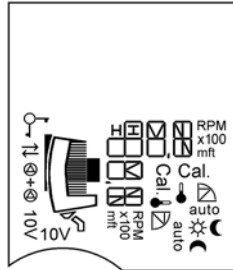
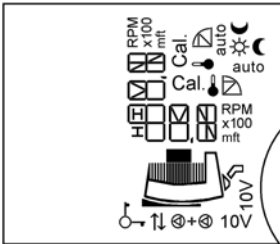

Horizontal

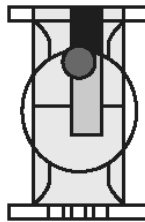





Vertical

Positional setting
in menu item 3

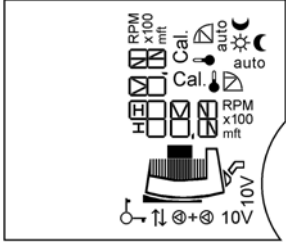
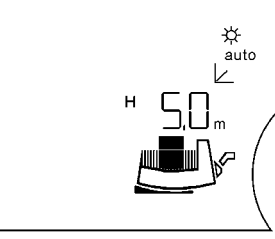
8.2.3 Settings in the menu

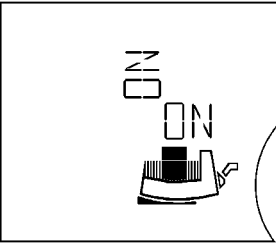
- The following menus appear one after another when operating the display of the single-head pump: (horizontal representation of the display)
 - Single-head pump operation:initial commissioning setting / menu sequence in running operation

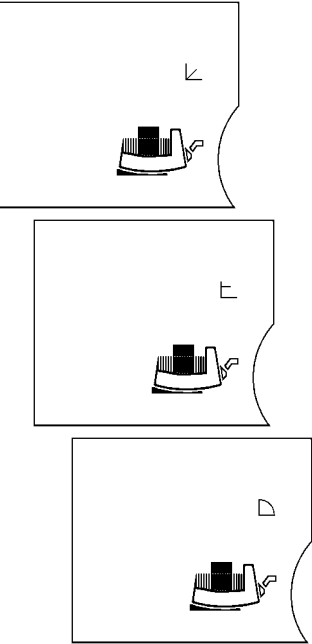
LC display	Setting						
<p>①</p> 	<p>All symbols appear on the display for 2 seconds when the module is switched on. The current setting ② is then displayed.</p>						
<p>②</p> 	<p>Current (basic) setting (works setting):</p> <table border="1"> <tr> <td>auto ☀ →</td> <td>Enables setback mode, pump runs in control mode</td> </tr> <tr> <td>⊙ ⊙ missing →</td> <td>Single-head pump → Nominal delivery head H_s = 5.0 m with $\frac{1}{2} H_{max}$ at the same time (works setting depends on pump type)</td> </tr> <tr> <td>↙ →</td> <td>Δp-v control mode</td> </tr> </table> <p>↻ The differential pressure setpoint is adjusted by turning the control button. The new differential pressure setpoint flashes.</p> <p>↓ The new setting is saved by briefly pressing the button. The flashing differential pressure setpoint previously set is reset to the previous value if no button is pressed within 30 seconds.</p> <p>↓ Press operating button > 1 second. The next menu item ③ appears.</p>	auto ☀ →	Enables setback mode, pump runs in control mode	⊙ ⊙ missing →	Single-head pump → Nominal delivery head H_s = 5.0 m with $\frac{1}{2} H_{max}$ at the same time (works setting depends on pump type)	↙ →	Δp -v control mode
auto ☀ →	Enables setback mode, pump runs in control mode						
⊙ ⊙ missing →	Single-head pump → Nominal delivery head H_s = 5.0 m with $\frac{1}{2} H_{max}$ at the same time (works setting depends on pump type)						
↙ →	Δp -v control mode						
<p>The basic setting is displayed again if no setting is made in the subsequent menu within 30 seconds ②.</p>							

LC display	Setting
<p>③</p> 	<p>Vertical /horizontal positional setting of the display The set position of the display is indicated by "ON" flashing.</p> <hr/> <p> The other position is selected by turning the control button.</p> <hr/> <p> The setting is applied.</p>
<p>④</p> 	<p>The control mode currently set flashes.</p> <hr/> <p> Other control modes can be selected by turning the control button. The newly selected control mode flashes.</p> <hr/> <p> The new control mode is applied and the next menu opened by pressing the button.</p>

LC display

Setting

5

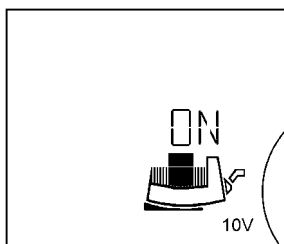

Menu item 5 only appears if a Stratos-IF module with 0 - 10 V input is connected.
Switching the 0 - 10 V input on / off

Activating the 0 - 10 V input: "ON" and the "module motor symbol" are displayed.



The setting can be changed by turning the control button.

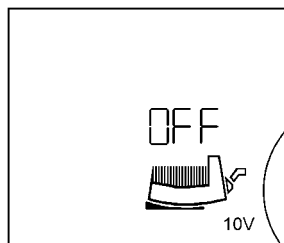

Deactivating the 0 - 10 V input: "OFF" is displayed.



The setting is applied.

Menu item 7a is opened once the input has been switched on.

6

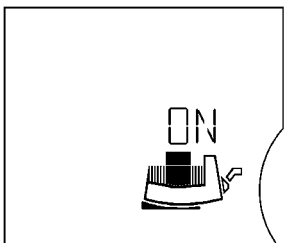

Switching the pump on / off

Switching on the pump: "ON" and the "module motor symbol" are displayed.



The setting can be changed by turning the control button.





Switching off the pump: "OFF" is displayed.

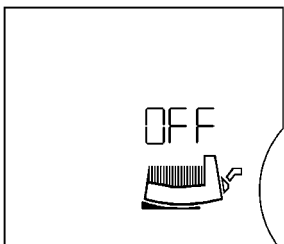

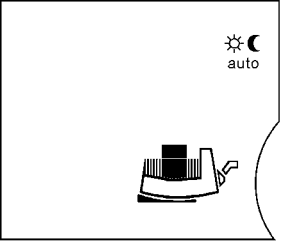

The setting is applied.







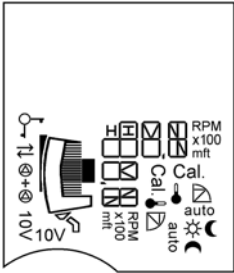
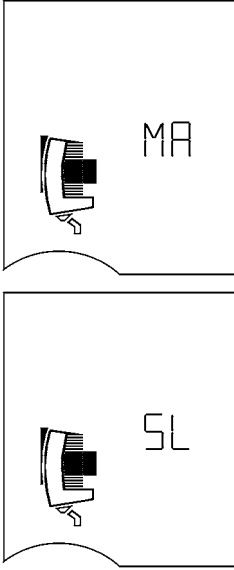

The "motor symbol" disappears when the pump is switched off.

LC display	Setting
<p>⑦</p> 	<p>One of the following two symbols flashes:</p> <hr/> <p>auto ☾ → Enables setback mode. In menu item ② “auto ☼” is displayed in automatic control mode or “auto ☾” in setback mode.</p> <hr/> <p>☼ → Normal control mode, setback mode disabled. In this case menu item ② is without a symbol.</p> <hr/> <p> Select one of the two settings</p> <hr/> <p> and apply it.  The next menu is displayed.</p> <hr/> <p>Menu item ⑦ is skipped if:</p> <ul style="list-style-type: none"> - The pump is operated at PLR/LON/CAN. - Manual control mode has been selected. - The 0...10 V input has been activated.
<p>⑦a</p> 	<p>In single-head pump mode, the display returns to the basic setting ②.</p> <p>The fault menu ⑩ appears prior to the basic setting ② in the event of a fault In twin-head pump mode, the display goes to menu ⑧.</p>

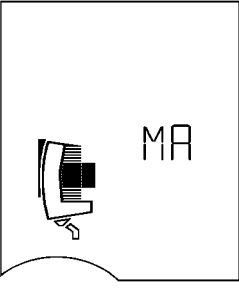

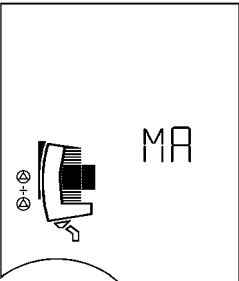
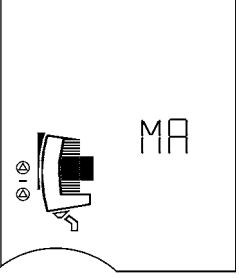



- Twin-head pump mode: initial commissioning setting (vertical display representation)



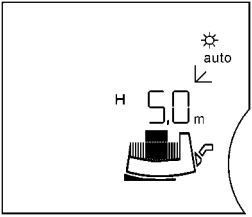

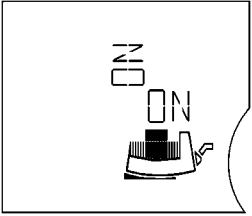
LC display	Setting
<p>①</p> 	<p>All symbols appear on the display for two seconds after switching on the module. Then menu ①a appears.</p>
<p>①a</p> 	<p>The symbol MA = master appears on both pump displays. If no setting is made, both pumps run at constant differential pressure ($H_s = \frac{1}{2} H_{max}$ with $Q = 0 \text{ m}^3/\text{h}$).</p> <p>The operating mode setting menu ⑨ appears on the display by  on the control button of the left pump. SL = slave automatically appears on the right-hand pump display.</p> <p>The left pump is now defined as master, the right pump as slave. The control button on the slave pump is no longer active. No settings can be made here.</p> <p>The position of the display cannot be set at the slave pump. The positional setting at the slave pump is specified by the master pump.</p>

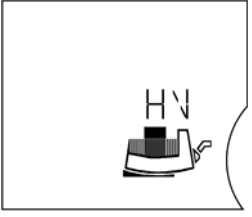
- Twin-head pump mode: menu sequence in running operation
All symbols ① appear on the display for two seconds when the module is switched on. The current setting ② is then displayed. The same menu sequence ②...⑦ appears as with the single-head pump when “scrolling” through the master display. The MA menu is then permanently displayed.

LC display	Setting
<p>⑧</p> 	<p>SL appears on this display by ↶↷ on MA. The other (right-hand) pump becomes the master if SL is confirmed by  Master and slave have now been exchanged. Programming can now only be performed on the right-hand (MA) pump. Settings cannot be made at the SL. Master and slave can only be exchanged at the master.</p>
<p>⑨</p>  	<p>Peak load or main /standby mode setting The current setting is lit up.</p> <hr/> <p> The other setting is lit up.</p> <hr/> <p> The setting is applied.</p> <hr/> <p> Display returns to the basic setting ②.</p>

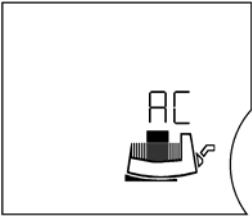
- **Options menu: Selection of operating mode Heating (HV) / Refrigeration Air-conditioning (AC) and conversion from SI to US units**

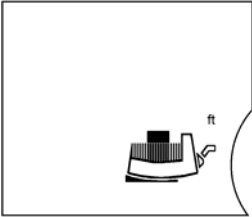
LC display	Setting
<p>②</p> 	<p> In the basic settings (menu level 1), press the operating button for > 6 s.</p>
<p>③</p> 	<p> After approx. 1 s, the menu level 2 appears (position setting of the display screen).</p>
	<p> After another 5 s, the display switches to the menu level 3</p> <p>The HV display appears (works setting).</p>

LC display	Setting
	<p data-bbox="470 181 524 213"></p> <p data-bbox="553 172 956 252">Rotating the control button will switch the setting to the cooling/air-conditioning (AC) operating mode.</p> <p data-bbox="454 290 539 341"></p> <p data-bbox="553 290 777 316">The setting is applied.</p> <p data-bbox="553 347 833 373">The next menu is displayed.</p>
	<p data-bbox="553 466 956 545">The display "m ft" appears, for which the unit that is set will be flashing. (Works setting [m]).</p> <p data-bbox="470 568 524 600"></p> <p data-bbox="553 552 945 632">Rotating the control button will change the setting to [ft]. The new setting will begin flashing.</p> <p data-bbox="454 641 539 692"></p> <p data-bbox="553 641 956 692">The new setting is saved by briefly pressing the button.</p> <p data-bbox="553 727 934 753">Display returns to the basic setting ②.</p>
<p data-bbox="138 788 956 839">If no setting is made in the subsequent menu within 30 s, then the display will once again show the basic setting ②.</p>	

• **Fault display: single-head and twin-head pump**

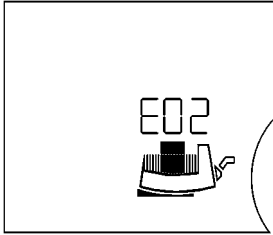
LC display	Setting
<p>⑩</p> 	<p>If a fault occurs, the current fault is indicated by E = error, the code no. and by the error source motor, control module or mains connection flashing.</p> <p>Refer to Chapter 10 for code numbers and their meaning</p>

8.3 Selection of the control mode

System type	System conditions	Recommended control mode
<p>Heating/ventilation/air-conditioning systems with resistance in the transfer section (room radiator + thermostatic valve) $\leq 25\%$ of the total resistance</p> <p>Secondary hot water circulation systems with resistance in the generator circuit $\geq 50\%$ of the resistance in the ascending pipe</p>	<ol style="list-style-type: none"> Two-pipe systems with thermostatic/zone valves and low valve authority <ul style="list-style-type: none"> $H_N > 4$ m Very long valve lines Strongly throttled line shutoff valves Line differential pressure controller High pressure losses in the system parts through which the entire volume flows (boiler/refrigerating machine, heat exchanger possibly, distribution pipeline up to the first branch) Primary circuits with high pressure losses Secondary hot water circulation systems with thermostatically controlled line shutoff valves 	<p>$\Delta p-v$</p>

System type	System conditions	Recommended control mode
<p>Heating/ventilation/air-conditioning systems with resistance in the generator/distribution circuit $\leq 25\%$ of the resistance in the transfer section (room radiator + thermostatic valve)</p> <p>Secondary hot water circulation systems with resistance in the generator circuit $\leq 50\%$ of the resistance in the ascending pipe</p>	<ol style="list-style-type: none"> 1. Two-pipe systems with thermostatic/zone valves and high valve authority <ul style="list-style-type: none"> • $H_N \leq 2$ m • Converted gravity heating systems • Conversion to large temperature difference (e.g. district heating) • High pressure losses in the system parts through which the entire volume flows (boiler/refrigerating machine, heat exchanger possibly, distribution pipeline up to the first branch) 2. Primary circuits with low pressure losses 3. Floor heating systems with thermostatic or zone valves 4. One-pipe systems with thermostatic or line shutoff valves 5. Secondary hot water circulation systems with thermostatically controlled line shutoff valves 	$\Delta p-c$
Heating systems	<ol style="list-style-type: none"> 1. Two-pipe systems <ul style="list-style-type: none"> • Pump is installed in the flow pipe. • The flow temperature is controlled by atmospheric conditions. The volume flow increases together with the flow temperature. 2. One-pipe systems <ul style="list-style-type: none"> • Pump is installed in the return pipe. • The flow temperature is constant. The volume flow falls as the return temperature rises. 3. Primary circuits with condensing boiler <ul style="list-style-type: none"> • Pump is installed in the return pipe. The volume flow decreases as the return temperatures rises. 	$\Delta p-T$

System type	System conditions	Recommended control mode
Secondary hot water circulation systems	4. Secondary hot water circulation systems with thermostatically controlled line shutoff valves or constant volume flow. The volume flow decreases as the return temperature rises.	
Heating-ventilation/air-conditioning systems Secondary hot water circulation systems	1. Constant volume flow	Manual control mode
Heating systems	1. All systems <ul style="list-style-type: none"> • Pump is installed in the flow pipe. • The flow temperature falls during low load periods (e.g. at night). • Pump runs 24 hours without external control at the mains. 	“Autopilot” setback mode

8.4 Setting the pump performance

During the planning phase the system is designed for a certain duty point (hydraulic peak load point for calculated maximum heating requirement). The pump performance (delivery head) is set during commissioning according to the duty point of the system (see also 4.3). The factory setting does not correspond to the pump performance required for the system. It is determined by means of the curve diagram for the selected pump type (from catalogue/data sheet). See also Fig. 8 to 10.

Δp -c, Δp -v and Δp -T control modes:

	Δp -c (Fig. 9)	Δp -v (Fig. 8)	Δp -T (Fig. 10)
Duty point on maximum curve	Draw from the duty point towards the left. Read the setpoint H_s and set the pump to this value.		Settings should be made by after-sales service via LON/CAN or with the IR monitor/IR module, taking into account the system conditions.
Duty point within the control range	Draw from the duty point towards the left. Read the setpoint H_s and set the pump to this value.	Go along the control curve up to the maximum curve, then move horizontally to the left. Read the setpoint H_s and set the pump to this value.	
Adjustment range	See 1.2.1 Type key for H_{\min} , H_{\max}		T_{\min} : 20 ... 100 °C T_{\max} : 30 ... 110 °C $\Delta T = T_{\max} - T_{\min} \geq 10$ °C Gradient: $\Delta H_s / \Delta T \leq 1$ m/10 °C H_{\min} , H_{\max} Positive operation setting: $H_{\max} > H_{\min}$ Negative operation setting: $H_{\min} > H_{\max}$

9 Maintenance

Have maintenance and repair work carried out by qualified personnel only.



WARNING! Danger of electric shock!

Any danger from electrical current should be ruled out.

- The pump should be electrically isolated and secured against unauthorised switch-on prior to any maintenance or repair work.
- Any damage to the connection cable should always be rectified by a qualified electrician only.



WARNING! Risk of scalding!

At high fluid temperatures and system pressures, allow the pump to cool down first and then depressurise the system.



CAUTION! Risk of material damage!

If the motor head is disconnected from the pump housing during service or maintenance work, the O-ring between the motor head and pump housing must be replaced by a new one. Make sure the O-ring is fitted properly when installing the motor head.

10 Faults, causes and remedies

Refer to the “Fault signal / warning message” sequence display and **Tables 10, 10.1, 10.2** when handling faults..

Faults	Causes	Remedy
Pump is not running although the current entry is switched on.	Electric fuse defective.	Check the fuses.
	Pump has no voltage.	Resolve the voltage interruption.
Pump is making noises.	Cavitation due to insufficient suction pressure.	Increase the system admission pressure within the admissible range.
		Check the delivery head and set it to a lower height if necessary.

Table 10: Faults with external fault sources

10.1 Fault signals – Heating/ventilation HV operating mode

- A fault occurs.
- The pump switches off, the fault signal LED (red steady light) switches on.
Twin-head pump: the standby pump is switched on.
- The pump automatically goes on again after a delay of five minutes.
- The pump is permanently switched off, SSM opens and the PLR/LON/CAN interface transmits the fault signal only if the same fault occurs for the sixth time within 24 hours. The fault must then be reset by hand.



EXCEPTION: If the warnings “E10” and “E25” in HV operating mode are pending for longer than 5 min, they are relayed as fault signals.

10.2 Fault signals – Air-conditioning AC operating mode

- A fault occurs.
- The pump switches off, the fault signal LED (continuous red light) is activated. The fault signal appears in the display, SSM opens and the interface PLR/LON/CAN passes along the fault signal. The malfunction must then be reset manually or via CAN.

Twin-head pump: The standby pump is switched on.



NOTE: Cod-Nrn “E04” (mains undervoltage) and “E05” (mains overvoltage) are treated as faults only in AC operation and lead to immediate deactivation.

Code no.	Symbol flashing	Fault	Cause	Remedy
E04	Line terminal	Mains undervoltage	Mains overloaded	Check electrical installation
E05	Line terminal	Mains overvoltage	Faulty supply by the electricity supply company	Check electrical installation
E10	Motor	Pump blockage	E.g. due to deposits	Unblocking routine starts automatically. Pump switches off if blockage is not cleared within max. 40 seconds. Request after-sales service
E20	Motor	Excess winding temperature	Motor overloaded	Allow motor to cool down, check setting.
			Water temperature too high	Lower water temperature
E21	Motor	Motor overload	Deposits in the pump	Request after-sales service
E23	Motor	Short circuit/earth leakage	Motor defective	Request after-sales service
E25	Motor	Faulty contact	Module not connected properly	Re-connect module
E30	Module	Excess module temperature	Limited air supply to the dissipator of the module	Provide unobstructed air access
E31	Module	Excess power section temperature	Ambient temperature too high	Improve room ventilation
E36	Module	Module defective	Electronic components defective	Request after-sales service/replace module

Table 10.1: Fault signals

10.3 Warning messages

- The fault (warning only) is displayed.
- The fault signal LED and the SSM relay do not respond.
- The pump continues to run. The fault may occur any amount of times.
- The indicated faulty operating state must not occur for a long period of time. The cause should be eliminated.



EXCEPTION: If the “E04” and “E05” in HV operation warnings apply for longer than 5 minutes, they are transmitted as fault signals (see Section 10.1).

Code no.	Symbol flashing	Fault	Cause	Remedy
E03		Water temperature >110 °C	Heating control set incorrectly	Set to lower temperature
E04		Mains undervoltage	Mains overloaded	Check electrical installation
E05		Mains overvoltage	Faulty supply by the electricity supply company	Check electrical installation
E07		Dynamic operation	Driven by the admission pressure pump (pump perfusion from the suction to the pressure side)	Balance power control of pumps
E09		Turbine operation	The pump is driven backwards (pump perfusion from the pressure to the suction side)	Check perfusion, install non-return valves if necessary.
E11		Pump idling	Air in the pump	Bleed the pump and system
E38	Motor	Fluid temp. sensor defective	Motor defective	Request after-sales service
E50		PLR/LON/CAN communication fault	Interface, core defective, IF modules not connected properly, cable defective	The control system is switched to local mode control via the interface after 5 minutes.
E51		Impermissible combination	Different pumps	
E52		Master/slave communication fault	Stratos IF modules not correctly plugged, cable defective	The modules switch over to single pump head operation after 5 min. Plug modules back in, check cables

Code no.	Symbol flashing	Fault	Cause	Remedy
E53		Non- authorised CAN address	Same CAN address assigned twice	Carry out addressing on the module once again
E54		Connection I/O – module	Connection I/O – module interrupted	Check connection
MA		Master/slave not set		Define the master and slave

Table 10.2: Warning messages

If the operating fault is unable to be eliminated, please contact a skilled craft firm or the nearest Wilo after-sales service point or representative.

Process presentation Fault/warning signal in HV operation

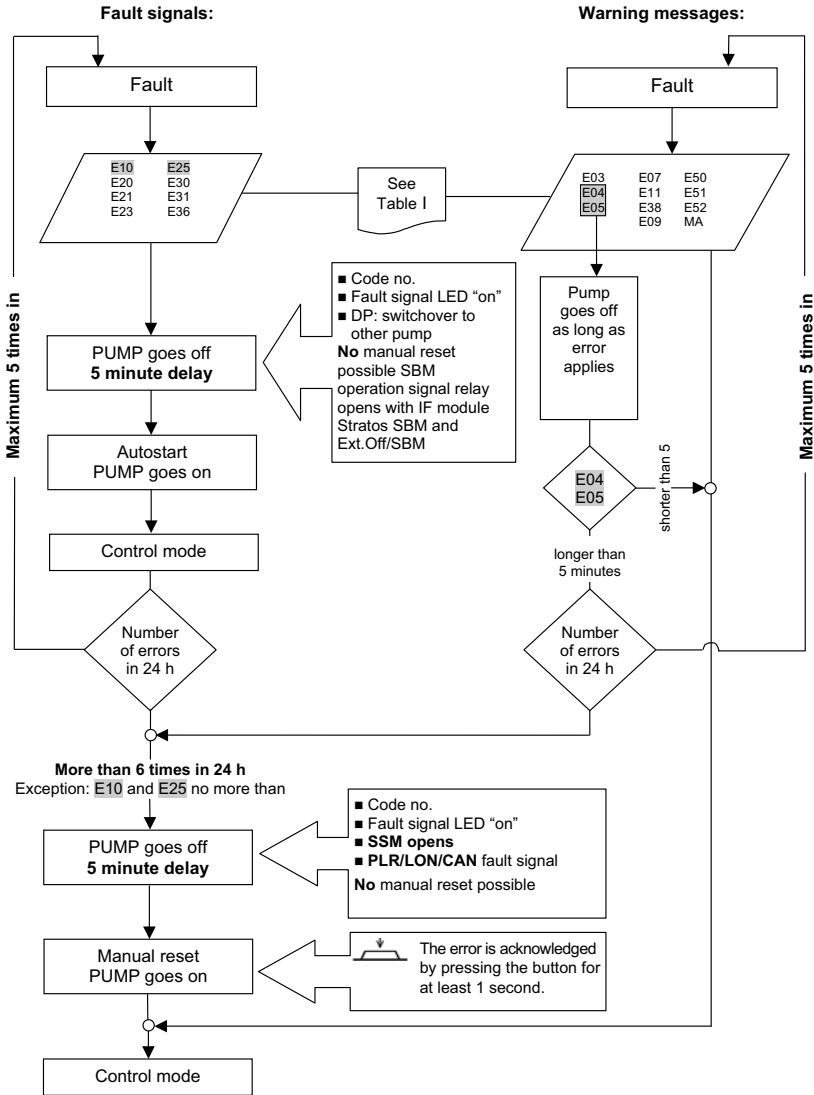

Process presentation Fault/warning signal in AC operation

Process presentation Fault/warning signal in AC operation

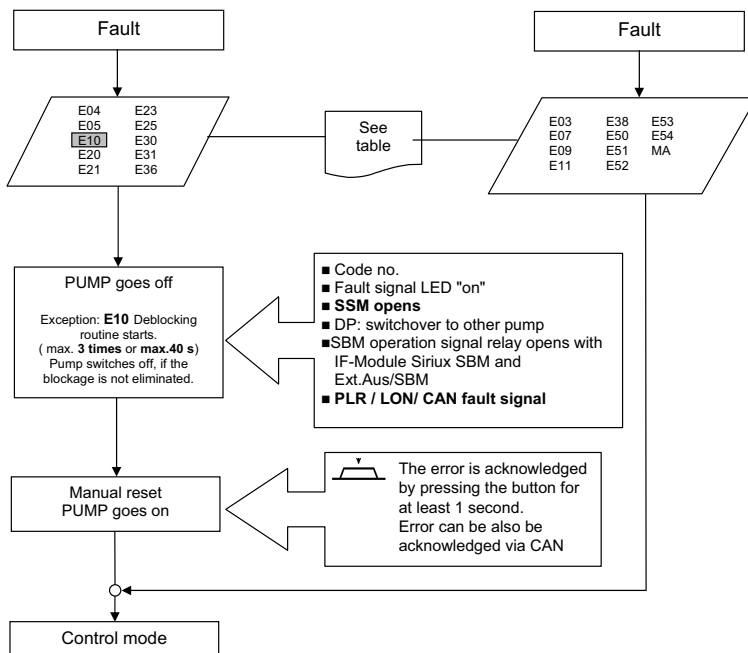

11 Spare parts

Spare parts are ordered via local specialists and/or Wilo after-sales service. To avoid queries and incorrect orders, all data on the name plate should be submitted for each order.

D EG – Konformitätserklärung

GB EC – Declaration of conformity

F Déclaration de conformité CE

(gemäß Anhang / according annex / conforme appendice 1A, 2006/42/EG)

Hiermit erklären wir, dass die Bauart der Baureihe :
Herewith, we declare that the product type of the series:
Par le présent, nous déclarons que l'agrégat de la série :

Stratos
Stratos-D
Stratos-Z

in der gelieferten Ausführung folgenden einschlägigen Bestimmungen entspricht:
in its delivered state complies with the following relevant provisions:
est conforme aux dispositions suivantes dont il relève:

EG-Maschinenrichtlinie
EC-Machinery directive
Directives CE relatives aux machines

2006/42/EG

Die Schutzziele der Niederspannungsrichtlinie werden gemäß Anhang I, Nr. 1.5.1 der Maschinenrichtlinie 2006/42/EG eingehalten.

The protection objectives of the low-voltage directive are realized according annex I, No. 1.5.1 of the EC-Machinery directive 2006/42/EC.

Les objectifs protection de la directive basse-tension sont respectées conformément à appendice I, n° 1.5.1 de la directive CE relatives aux machines 2006/42/CE.

Elektromagnetische Verträglichkeit - Richtlinie
Electromagnetic compatibility - directive
Compatibilité électromagnétique- directive

2004/108/EG

Angewendete harmonisierte Normen, insbesondere:
Applied harmonized standards, in particular:
Normes harmonisées, notamment:

EN 809
EN 12100-1
EN 12100-2
EN 14121-1
EN 61800-3
EN 61800-5-1
EN 60335-1
EN 60335-2-51

Bei einer mit uns nicht abgestimmten technischen Änderung der oben genannten Bauarten, verliert diese Erklärung ihre Gültigkeit.
If the above mentioned series are technically modified without our approval, this declaration shall no longer be applicable.
Si les gammes mentionnées ci-dessus sont modifiées sans notre approbation, cette déclaration perdra sa validité.

Bevollmächtigter für die Zusammenstellung der technischen Unterlagen ist:
Authorized representative for the completion of the technical documentation is:
Mandataire pour le complément de la documentation technique est :

Gerhard Hunnekuhl
Nortkirchenstraße 100
44263 Dortmund
Germany

Dortmund, 30.11.2009

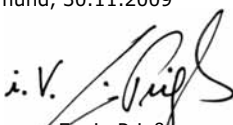
i. V. 
Erwin Prieb
Quality Manager



WILO SE
Nortkirchenstraße 100
44263 Dortmund
Germany

<p>NL EG-verklaring van overeenstemming Hiermede verklaren wij dat dit aggregaat in de geleverde uitvoering voldoet aan de volgende bepalingen: EG-richtlijnen betreffende machines 2006/42/EG Elektromagnetische compatibiliteit 2004/108/EG en overeenkomstige nationale wetgeving gebruikte geharmoniseerde normen, in het bijzonder: zie vorige pagina</p>	<p>I Dichiarazione di conformità CE Con la presente si dichiara che i presenti prodotti sono conformi alle seguenti disposizioni e direttive rilevanti: Direttiva macchine 2006/42/EG Compatibilità elettromagnetica 2004/108/EG e le normative nazionali vigenti norme armonizzate applicate, in particolare: vedi pagina precedente</p>	<p>E Declaración de conformidad CE Por la presente declaramos la conformidad del producto en su estado de suministro con las disposiciones pertinentes siguientes: Directiva sobre máquinas 2006/42/EG Directiva sobre compatibilidad electromagnética 2004/108/EG y la legislación nacional vigente normas armonizadas adoptadas, especialmente: véase página anterior</p>
<p>P Declaração de Conformidade CE Pela presente, declaramos que esta unidade no seu estado original, está conforme os seguintes requisitos: Directivas CE relativas a máquinas 2006/42/EG Compatibilidade eletromagnética 2004/108/EG e respectiva legislação nacional normas harmonizadas aplicadas, especialmente: ver página anterior</p>	<p>S CE- försäkrän Härmed förklarar vi att denna maskin i levererat utförande motsvarar följande tillämpliga bestämmelser: EG-Maskindirektiv 2006/42/EG EG-Maskindirektiv 2006/42/EG og gällande nationell lagstiftning tillämpade harmoniserade normer, i synnerhet: se föregående sida</p>	<p>N EU-Overensstemmelseerklaring Vi erklærer hermed at denne enheten i utførelse som levert er i overensstemmelse med følgende relevante bestemmelser: EG- Maskindirektiv 2006/42/EG EG-EMV – Elektromagnetisk kompatibilitet 2004/108/EG og tilsvarende nasjonal lovgivning anvendte harmoniserte standarder, særlig: se forrige side</p>
<p>FIN CE-standardinmukaissuuseloste Ilmoitamme täten, että tämä laite vastaa seuraavia asiaankuuluvia määräyksiä: EU-kone-direktiiviti: 2006/42/EG Sähkömagneettinen soveltuvuus 2004/108/EG ja vastaava kansallista lainsäädäntöä käytetty yhteensovitetut standardit, erityisesti: katso edellinen sivu.</p>	<p>DK EF-overensstemmelseerklaring Vi erklærer hermed, at denne enhed ved levering overholder følgende relevante bestemmelser: EG-maskindirektiv 2006/42/EG Elektromagnetisk kompatibilitet: 2004/108/EG og gældende national lovgivning anvendte harmoniserede standarder, særligt: se forrige side</p>	<p>H EK-megfelelőeségi nyilatkozat Ezennel kijelentjük, hogy az berendezés megfelel az alábbi irányelveknek: Gépek irányelvei: 2006/42/EK Elektromágneses összeférhetőség irányelvei: 2004/108/EK valamint a vonatkozó nemzeti törvényeknek és alkalmazott harmonizált szabványoknak, különösen: lásd az előző oldalt</p>
<p>CZ Prohlášení o shodě ES Prohláámé tímto, že tento agregát v dodaném provedení odpovídá následujícím příslušným ustanovením: Směrnice ES pro strojí zařízen 2006/42/ES Směrnice o elektromagnetické kompatibilitě 2004/108/ES a příslušným národním předpisům použité harmonizační normy, zejména: viz předchozí strana</p>	<p>PL Deklaracja Zgodności WE Niniejszym deklarujemy z pełną odpowiedzialnością, że dostarczony wyrób jest zgodny z następującymi dokumentami: dyrektywą maszynową WE 2006/42/WE dyrektywą dot. kompatybilności elektromagnetycznej 2004/108/WE oraz odpowiednimi przepisami ustawodawstwa krajowego stosowanymi normami zharmonizowanymi, a w szczególności: patrz poprzednia strona</p>	<p>RUS Декларация о соответствии Европейским нормам Настоящим документом заявляем, что данный агрегат в его объеме поставки соответствует следующим нормативным документам: Директивы ЕС в отношении машин 2006/42/EG Электромгнитная устойчивость 2004/108/EG в соответствии с национальным законодательством Используемые согласованные стандарты и нормы, в частности: см. предыдущую страницу</p>
<p>GR Αήλωση συμμόρφωσης της ΕΕ Αηλώνουμε ότι το προϊόν αυτό ο' αυτή την κατάσταση παράδοσης ικανοποιεί τις ακόλουθες διατάξεις: Οδηγίες ΕΚ για μηχανήματα 2006/42/ΕΚ Ηλεκτρομαγνητική συμβατότητα ΕΚ-2004/108/ΕΚ καθώς και την αντίστοιχη κρατική νομοθεσία Εναρμονισμένα χρησιμοποιούμενα πρότυπα, ιδιαίτερα: βλέπε προηγούμενη σελίδα</p>	<p>TR CE Uygunluk Tevdi Belgisi Bu cihazın teslim edildiği şekliyle aşağıdaki standartlara uygun olduğunu tevdi ederiz: AB-Makina Standartları 2006/42/EG Elektromanyetik Uyumluluk 2004/108/EG ve söz konusu ulusal yasalara. kismen kulllanılan standartlar için: bkz. bir önceki sayfa</p>	<p>RO EC-Declarație de conformitate Prin prezenta declarăm că acest produs așa cum este livrat, corespunde cu următoarele prevederi aplicabile: Directiva CE pentru mașini 2006/42/EG Compatibilitatea electromagnetică – directiva 2004/108/EG și legislația națională respectivă standarde armonizate aplicate, îndeosebi: vezi pagina precedentă</p>
<p>EST EÜ vastavusdeklaratsioon Käesolevaga tõendame, et see toode vastab järgmistele asjakohastele direktiividele: Masinadirektiiv 2006/42/EÜ Elektromagnetilise ühilduvuse direktiiv 2004/108/EÜ ja vastavalt asjaomastele siseriiklikele õigusaktidele kohaldatud harmoneeritud standardid, eriti: vt eelmist lk</p>	<p>LV EC – atbilstības deklarācija Ar šo mēs apliecinām, ka šis izstrādājums atbilst sekojošiem noteikumiem: Masīnu direktīva 2006/42/EK Elektromagnētiskās savietojamības direktīva 2004/108/EK un atbilstoši nacionālajai likumdošanai piemēroti harmonizēti standarti, tai skaitā: skatīt iepriekšējo lappusi</p>	<p>LT EB atitikties deklaracija Šiuo pažymima, kad šis gaminyas atitinka šias normas ir direktyvas: Masīnu direktyva 2006/42/EB Elektromagnetinio suderinamumo direktiva 2004/108/EB bei atitinkamiems šalies įstatymams pritaikytus vieningus standartus, o būtent: žr. ankstesniame puslapyje</p>
<p>SK ES vyhlášení o zhode Týmto vyhlasujeme, že konštrukcie tejto konštrukčnej série v dodanom vyhotovení vyhovujú nasledujúcim príslušným ustanoveniam: Stroje - smernica 2006/42/ES Elektromagnetická zhoda - smernica 2004/108/ES a zodpovedajúca vnútroštátna legislatíva používané harmonizované normy, najmä: pozri predchádzajúcu stranu</p>	<p>SLO ES – izjava o skladnosti Izjavljamo, da dobavljene vrste izvedbe te serije ustreza sledenim zaednim dolocilom: Direktiva o strojih 2006/42/ES Direktiva o elektromagnetni združljivosti 2004/108/ES in ustrežno nacionalnim zakonom uporabljeni harmonizirani standardi, predvsem: glejte prejšnjo stran</p>	<p>BG EO-Декларация за съответствие Декларираме, че продуктът отговаря на следните изисквания: Машина директива 2006/42/EO Електромагнитна съвместимост – директива 2004/108/EO и съответното национално законодателство Хармонизирани стандарти: вж. предната страница</p>
<p>M Dikjarazjoni ta' konformità KE B'dan il-mezz, niddikjaraw li l-prodotti tas-serje jissodisfaw id-dispożizzjonijiet rilevanti li ġejjin: Makkinarju - Direttiva 2006/42/KE Kompatibilità elettromagnetika - Direttiva 2004/108/KE kif ukoll standards armonizzati adottati fil-leġiżlazzjoni nazzjonali b' mod partikolari: ara l-paġna ta' qabel</p>	<div data-bbox="725 1337 893 1412" data-label="Image"> </div> <p>WILO SE Nortkirchenstraße 100 44263 Dortmund Germany</p>	

Wilo – International (Subsidiaries)

Argentina

WILO SALMSON
 Argentina S.A.
 C1295ABI Ciudad
 Autónoma de
 Buenos Aires
 T + 54 11 4361 5929
 info@salmson.com.ar

Austria

WILO Pumpen
 Österreich GmbH
 1230 Wien
 T +43 507 507-0
 office@wilo.at

Azerbaijan

WILO Caspian LLC
 1065 Baku
 T +994 12 5962372
 info@wilo.az

Belarus

WILO Bel OOO
 220035 Minsk
 T +375 17 2503393
 wibel@wilo.by

Belgium

WILO SA/NV
 1083 Ganshoren
 T +32 2 4823333
 info@wilo.be

Bulgaria

WILO Bulgaria Ltd.
 1125 Sofia
 T +359 2 9701970
 info@wilo.bg

Canada

WILO Canada Inc.
 Calgary, Alberta T2A 5L4
 T +1 403 2769456
 bil.lowe@wilo-na.com

China

WILO China Ltd.
 101300 Beijing
 T +86 10 58041888
 wiloobj@wilo.com.cn

Croatia

WILO Hrvatska d.o.o.
 10090 Zagreb
 T +38 51 3430914
 wilo-hrvatska@wilo.hr

Czech Republic

WILO Praha s.r.o.
 25101 Cestlice
 T +420 234 098711
 info@wilo.cz

Denmark

WILO Danmark A/S
 2690 Karlslunde
 T +45 70 253312
 wilo@wilo.dk

Estonia

WILO Eesti OÜ
 12618 Tallinn
 T +372 6509780
 info@wilo.ee

Finland

WILO Finland Oy
 02330 Espoo
 T +358 207401540
 wilo@wilo.fi

France

WILO S.A.S.
 78390 Bois d'Arcy
 T +33 1 30050930
 info@wilo.fr

Great Britain

WILO (U.K.) Ltd.
 DE14 2WJ Burton-
 Upon-Trent
 T +44 1283 523000
 sales@wilo.co.uk

Greece

WILO Hellas AG
 14569 Anixi (Attika)
 T +302 10 6248300
 wilo.info@wilo.gr

Hungary

WILO Magyarország Kft
 2045 Törökbálint
 (Budapest)
 T +36 23 889500
 wilo@wilo.hu

India

WILO India Mather and
 Platt Pumps Ltd.
 Pune 411019
 T +91 20 27442100
 service@

pun.matherplatt.co.in

Indonesia

WILO Pumps Indonesia
 Jakarta Selatan 12140
 T +62 21 7247676
 citrawilo@cbn.net.id

Ireland

WILO Engineering Ltd.
 Limerick
 T +353 61 227566
 sales@wilo.ie

Italy

WILO Italia s.r.l.
 20068 Peschiera
 Borromeo (Milano)
 T +39 25538351
 wilo.italia@wilo.it

Kazakhstan

WILO Central Asia
 050002 Almaty
 T +7 727 2785961
 in.pak@wilo.kz

Korea

WILO Pumps Ltd.
 621-807 Gimhae
 Gyeongnam
 T +82 55 3405890
 wilo@wilo.co.kr

Latvia

WILO Baltic SIA
 1019 Riga
 T +371 67 145229
 mail@wilo.lv

Lebanon

WILO SALMSON
 Lebanon
 12022030 El Metn
 T +961 4 722280
 wsl@cyberia.net.lb

Lithuania

WILO Lietuva UAB
 03202 Vilnius
 T +370 5 2136495
 mail@wilo.lt

The Netherlands

WILO Nederland b.v.
 1551 NA Westzaan
 T +31 88 9456 000
 info@wilo.nl

Norway

WILO Norge AS
 0975 Oslo
 T +47 22 804570
 wilo@wilo.no

Poland

WILO Polska Sp. z o.o.
 05-090 Raszyn
 T +48 22 7026161
 wilo@wilo.pl

Portugal

Bombas Wilo-Salmson
 Portugal Lda.
 4050-040 Porto
 T +351 22 2080350
 bombas@wilo.pt

Romania

WILO Romania s.r.l.
 077040 Com. Chiajna
 Jud. Ilfov
 T +40 21 3170164
 wilo@wilo.ro

Russia

WILO Rus ooo
 123592 Moscow
 T +7 495 7810690
 wilo@wilo.ru

Saudi Arabia

WILO ME – Riyadh
 Riyadh 11465
 T +966 1 4624430
 wshoula@watanaiand.com

Serbia and Montenegro

WILO Beograd d.o.o.
 11000 Beograd
 T +381 11 2851278
 office@wilo.co.yu

Slovakia

WILO Slovakia s.r.o.
 82008 Bratislava 28
 T +421 2 45520122
 wilo@wilo.sk

Slovenia

WILO Adriatic d.o.o.
 1000 Ljubljana
 T +386 1 8838130
 wilo.adriatic@wilo.si

South Africa

Salmson South Africa
 1610 Edenvale
 T +27 11 6082780
 errol.cornelius@
 salmson.co.za

Spain

WILO Ibérica S.A.
 28806 Alcalá de
 Henares (Madrid)
 T +34 91 8797100
 wilo.iberica@wilo.es

Sweden

WILO Sverige AB
 35246 Växjö
 T +46 470 727600
 wilo@wilo.se

Switzerland

EMB Pumpen AG
 4310 Rheinfelden
 T +41 61 83680-20
 info@emb-pumpen.ch

Taiwan

WILO-EMU Taiwan Co.
 Ltd.
 110 Taipei
 T +886 227 391655
 nelson.wu@
 wiloemutaiwan.com.tw

Turkey

WILO Pompa Sistemleri
 San. ve Tic. A.Ş.
 34530 Istanbul
 T +90 216 6610211
 wilo@wilo.com.tr

Ukraine

WILO Ukraine t.o.w.
 01033 Kiev
 T +38 044 2011870
 wilo@wilo.ua

United Arab Emirates

WILO Middle East FZE
 Jebel Ali – Dubai
 T +971 4 886 4771
 info@wilo.com.sa

USA

WILO-EMU USA LLC
 Thomasville,
 Georgia 31792
 T +1 229 5840097
 info@wilo-emu.com

WILO USA LLC

Melrose Park, Illinois
 60160
 T +1 708 3389456
 mike.easterley@
 wilo-na.com

Vietnam

WILO Vietnam Co Ltd.
 Ho Chi Minh City,
 Vietnam
 T +84 8 38109975
 nkminh@wilo.vn

Wilo – International (Representation offices)

Algeria

Bad Ezzouar, Dar El Beida
 T +213 21 247979
 chabane.hamdad@
 salmson.fr

Bosnia and Herzegovina

71000 Sarajevo
 T +387 33 714510
 zeljko.cvjetkovic@wilo.ba

Macedonia

1000 Skopje
 T +389 2 3122058
 valerij.vojneski@
 wilo.com.mk

Moldova

2012 Chisinau
 T +373 2 223501
 sergiu.zagorean@
 wilo.md

Tajikistan

734025 Dushanbe
 T +992 37 2232908
 farhod.rahimov@
 wilo.tj

Uzbekistan

100015 Tashkent
 T +998 71 1206774
 info@wilo.uz

Armenia

375001 Yerevan
 T +374 10 544336
 info@wilo.am

Georgia

0179 Tbilisi
 T +995 32 306375
 info@wilo.ge

Mexico

07300 Mexico
 T +52 55 55863209
 roberto.valenzuela@
 wilo.com.mx

Rep. Mongolia

Ulaanbaatar
 T +976 11 314843
 wilo@magicnet.mn

Turkmenistan

744000 Ashgabad
 T +993 12 345838
 wilo@wilo-tm.info



WILO SE
Nortkirchenstraße 100
44263 Dortmund
Germany
T 0231 4102-0
F 0231 4102-7363
wilo@wilo.com
www.wilo.de

Wilo-Vertriebsbüros in Deutschland

G1 Nord

WILO SE
Vertriebsbüro Hamburg
Beim Strohhause 27
20097 Hamburg
T 040 5559490
F 040 5559494
hamburg.anfragen@wilo.com

G3 Ost

WILO SE
Vertriebsbüro Dresden
Frankenring 8
01723 Kesselsdorf
T 035204 7050
F 035204 70570
dresden.anfragen@wilo.com

G5 Süd-West

WILO SE
Vertriebsbüro Stuttgart
Hertichstraße 10
71229 Leonberg
T 07152 94710
F 07152 947141
stuttgart.anfragen@wilo.com

G7 West

WILO SE
Vertriebsbüro Düsseldorf
Westring 19
40721 Hilden
T 02103 90920
F 02103 909215
duesseldorf.anfragen@wilo.com

G2 Nord-Ost

WILO SE
Vertriebsbüro Berlin
Juliusstraße 52-53
12051 Berlin-Neukölln
T 030 6289370
F 030 62893770
berlin.anfragen@wilo.com

G4 Süd-Ost

WILO SE
Vertriebsbüro München
Adams-Lehmann-Straße 44
80797 München
T 089 4200090
F 089 42000944
muenchen.anfragen@wilo.com

G6 Mitte

WILO SE
Vertriebsbüro Frankfurt
An den drei Hasen 31
61440 Oberursel/Ts.
T 06171 70460
F 06171 704665
frankfurt.anfragen@wilo.com

Kompetenz-Team Gebäudetechnik

WILO SE
Nortkirchenstraße 100
44263 Dortmund
T 0231 4102-7516
T 01805 R-U-F-W-I-L-O*
7-8-3-9-4-5-6
F 0231 4102-7666

Erreichbar Mo-Fr von 7-18 Uhr.

- Antworten auf
 - Produkt- und Anwendungsfragen
 - Liefertermine und Lieferzeiten
- Informationen über Ansprechpartner vor Ort
- Versand von Informationsunterlagen

Kompetenz-Team Kommune Bau + Bergbau

WILO EMU GmbH
Heimgartenstraße 1
95030 Hof
T 09281 974-550
F 09281 974-551

Erreichbar Mo-So von 7-18 Uhr.
In Notfällen täglich
auch von
18-7 Uhr.

Werkskundendienst Gebäudetechnik Kommune Bau + Bergbau Industrie

WILO SE
Nortkirchenstraße 100
44263 Dortmund
T 0231 4102-7900
T 01805 W-I-L-O-K-D*

9-4-5-6-5-3
F 0231 4102-7126
kundendienst@wilo.com

Erreichbar Mo-So von 7-18 Uhr.
In Notfällen täglich
auch von
18-7 Uhr.

- Kundendienst-
Anforderung
- Werksreparaturen
- Ersatzteilfragen
- Inbetriebnahme
- Inspektion
- Technische Service-
Beratung
- Qualitätsanalyse

Wilo-International

Österreich

Zentrale Wien:
WILO Pumpen
Österreich GmbH
Eitnergasse 13
1230 Wien
T +43 507 507-0
F +43 507 507-15

Vertriebsbüro Salzburg:
Gnigler Straße 56
5020 Salzburg
T +43 507 507-13
F +43 507 507-15

Vertriebsbüro
Oberösterreich:
Trattnachtalstraße 7
4710 Grieskirchen
T +43 507 507-26
F +43 507 507-15

Schweiz

EMB Pumpen AG
Gerstenweg 7
4310 Rheinfelden
T +41 61 83680-20
F +41 61 83680-21

Standorte weiterer Tochtergesellschaften

Argentinien,
Aserbaidschan, Belarus,
Belgien, Bulgarien, China,
Dänemark, Estland,
Finnland, Frankreich,
Griechenland,
Großbritannien, Indien,
Indonesien, Irland, Italien,
Kanada, Kasachstan, Korea,
Kroatien, Lettland, Libanon,
Litauen, Niederlande,
Norwegen, Polen, Portugal,
Rumänien, Russland,
Saudi-Arabien, Schweden,
Serbien und Montenegro,
Slowakei, Slowenien,
Spanien, Südafrika, Taiwan,
Tschechien, Türkei,
Ukraine, Ungarn, USA,
Vereinigte Arabische
Emirate, Vietnam

Die Adressen finden Sie
unter www.wilo.com.

Stand November 2009

* 14 Cent pro Minute aus dem deutschen Festnetz
der T-Com. Bei Anrufen aus Mobilfunknetzen sind
Preisabweichungen möglich.