

APPLICAZIONI

Elettropompe autoadescenti Jet garantiscono un'ottima resa idraulica e una notevole capacità di pressione. Possono aspirare fino a 8 mt. di profondità e sono in grado di funzionare perfettamente anche in presenza di acque miscelate a gas. Adatte per il sollevamento e la distribuzione negli impianti domestici a mezzo di piccoli e medi serbatoi (autoclavi).

APPLICATION

Selfpriming jet water pumps with a very high hydraulic performance and a considerable pressure capacity. Able to pump up to mt. 8 depth and work perfectly even in soda-water. Suitable for water lifting and distribution in domestic fittings by small and medium sized tanks.

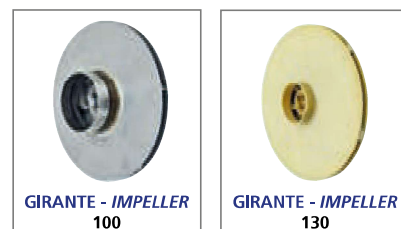

LIMITI D'IMPIEGO

- Temperatura liquido fino a 35°C (per un uso domestico secondo EN 60335-2-41)
- Temperatura max. liquido: 35°C (per altri impieghi)
- Temperatura ambiente fino a 40° C
- Altezza d'aspirazione manometrica fino a 8 mt.
- Servizio continuo

MOTORE

- Monofase 230V-50Hz
- Trifase 230/400V-50Hz
- Motore elettrico ad induzione a 2 poli (n = 2850 min⁻¹)
- Isolamento Classe F
- Protezione IP 44

MATERIALI

- | | |
|-------------------------|-----------------------|
| - Corpo pompa | Ghisa |
| - Supporto motore (100) | Ghisa |
| - Supporto motore (130) | Alluminio |
| - Girante (100) | Acciaio Inox AISI 304 |
| - Girante (130) | Noryl |
| - Diffusore | Noryl |
| - Albero motore | Acciaio Inox AISI 304 |
| - Tenute meccaniche | Ceramica/Grafite/NBR |

OPERATING CONDITIONS

- Liquid temperature up to 35°C (for home use according to EN 60335-2-41)
- Temperature max. liquid: 35°C (for other uses)
- Ambient temperature up to 40°C
- Total suction lift up to 8 mt.
- Continuous duty

MOTOR

- Single-phase 230V-50Hz
- Three-phase 230/400V-50Hz
- Two-Pole induction motor (n = 2850 min⁻¹)
- Insulation Class F
- Protection IP 44

MATERIALS

- | | |
|-----------------------|--------------------------|
| - Pump body | Cast Iron |
| - Motor Support (100) | Cast Iron |
| - Motor Support (130) | Aluminium |
| - Impeller (100) | Stainless Steel AISI 304 |
| - Impeller (130) | Noryl |
| - Diffuser | Noryl |
| - Shaft with rotor | Stainless Steel AISI 304 |
| - Mechanical seal | Ceramic/Graphite/NBR |

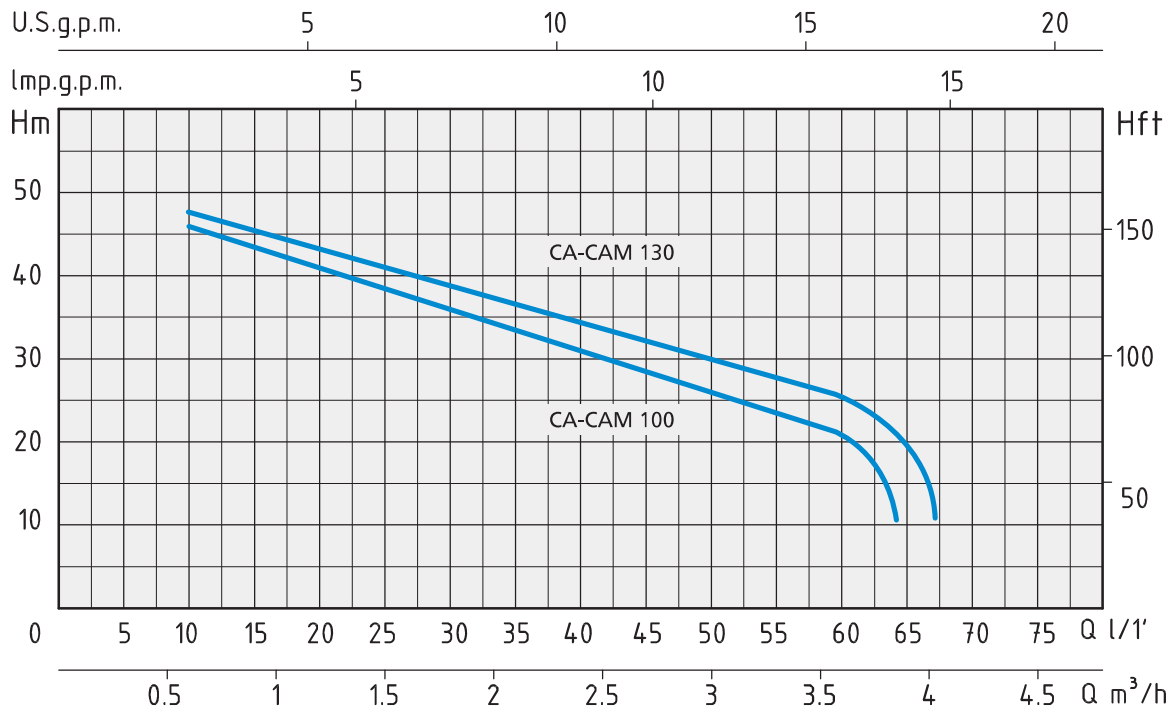

TIPO TYPE		POTENZA NOMINALE NOMINAL POWER		POTENZA ASSORBITA INPUT POWER	AMPERE		Q = PORTATA - CAPACITY										
Monofase Single-phase	Trifase Three-phase	P2		P1	Monofase Single-phase	Trifase Three-phase	m³/h	0,6	0,9	1,2	1,5	1,8	2,1	2,4	2,7	3	3,6
		HP	kW	kW			lt/1'	10	15	20	25	30	35	40	45	50	60
Prevalenza manometrica totale in m.C.A. - Total head in meters w.c.																	
CAM 100	CA 100	1	0,75	1,1	5	2,5	H	46	43	40	37	35	33	30	29	26	22
CAM 130	CA 130	1,3	1	1,3	5,8	2,8	(m)	47	44	43	40	39	36	35	32	30	25

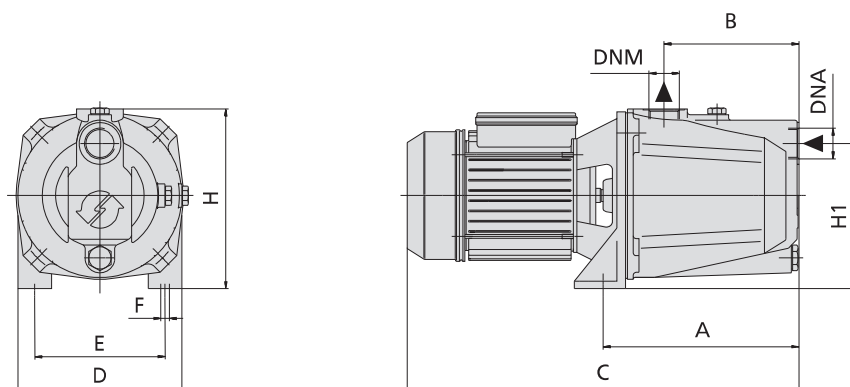

TIPO TYPE		DIMENSIONI mm - DIMENSIONS mm										DIMENSIONI DIMENSIONS mm			PESO WEIGHT
Monofase Single-phase	Trifase Three-phase	A	B	C	D	E	F	H	H1	DNA	DNM	P	L	H	Kg
CAM 100	CA 100	211	145	421	176	140	9	194	156	1"	1"	197	469	209	14,5
CAM 130	CA 130	211	145	421	176	140	9	194	156	1"	1"	197	469	209	15,1