



4.3-10 Male Hand-Screw Connector for 1/2" Coaxial SuperFlexibleCable, OMNI FIT™ standard

OMNI FIT™ high performance connectors are designed for use with both CELLFLEX® (copper) and CELLFLEX® Lite (aluminum) cables. They are designed specifically to provide the highest quality connector-cable interface while simplifying and speeding up connector attachment. All RFS connectors are fully tested for mechanical and electrical compliance to industry specifications. The 4.3-10 connector is an innovative, space-saving RF connection meeting all requirements even under the most severe environmental conditions and not relying on coupling nut torque to meet PIM performance. Hand-Screw attachment mechanism that is ideal for indoor and outdoor spaces where installation must be completed using only one hand.



43MH-SCF12-C03

FEATURES / BENEFITS

- Cost effective two-piece design for safe and easy installation
- Robust mechanical design for low and consistent intermodulation performance i.e. keeps the mobile network performance up, reduces the number of dropped calls and avoids revenue losses
- Standard electrical performance for consistent and repeatable VSWR i.e. ensure network system performance
- Waterproof to IP 68 i.e. no downtime risk, secures revenue
- RoHS (EU) compliant i.e. can be used on a global basis
- Hand-Screw Type connector could be torqued by hand, possesses special feature to prevent unwanted loosening of the coupling nut which could fit for both indoor and outdoor application where small installation space is required to accommodate one of the hands

Technical Features

GENERAL SPECIFICATIONS

Transmission Line Type		Coaxial Cable
Cable Size		1/2"
Cable Type		Foam Dielectric Superflexible
Model Series		SCF12-50 Series
Connector Interface		4.3-10 Hand-Screw
Connector Type		OMNI FIT™ Standard
Sealing Method		O-ring
Gender		Male

ELECTRICAL SPECIFICATIONS

Nominal Impedance	Ohm	50
3rd Order IM Product @ 2x20 Watts	dBc	-160 typical
Maximum Frequency	GHz	6.0
VSWR, Return Loss	VSWR (dB)	0 < f ≤ 1.0 GHz: 1.03 (36.6) 1.0 < f ≤ 2.7 GHz: 1.04 (34.1) 2.7 < f ≤ 3.7 GHz: 1.08 (28.3) 3.7 < f ≤ 5.0 GHz: 1.10 (26.4) 5.0 < f ≤ 6.0 GHz: 1.25 (19.1)

MECHANICAL SPECIFICATIONS

Plating Outer/Inner		Trimetal/Silver
Length	mm (in)	43.9 (1.73)
Outer Diameter	mm (in)	25 (1)
Weight	kg (lb)	0.072 (0.16)
Inner Contact Attachment		Basket
Outer Contact Attachment		Rigidity impaction

ACCESSORIES

Wrench size front	mm (in)	18 (3/4)
Wrench size rear	mm (in)	18 (3/4)
Trimming Tool		TRIM-SET-S12-C02

TESTING AND ENVIRONMENTAL

Waterproof Level		IP68
------------------	--	------



4.3-10 Male Hand-Screw Connector for 1/2" Coaxial SuperFlexibleCable, OMNI FIT™ standard

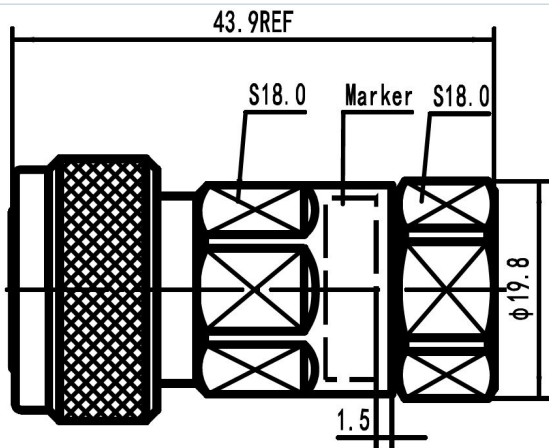

43MH-SCF12-C03 Outline drawing

External Document Links

Installation Instruction

Notes