

Universal connector grounding kit

These universal connector grounding kit provides a reliable ground connection to the connector body. Suitable for coaxial cable connectors from LCF 1/2" to 2-1/4" cable diameter. Up to 2 grounding wires with 2.5 up to 25 mm² cross section or round conductor with max. diameter of 8mm can be connected.



CEAR-12-214

FEATURES / BENEFITS

- ➡ Simple installation on site. No special tools required. All parts are loss proof pre-assembled.
- ➡ All components are made of stainless steel. Suitable for outdoor installation.
- ➡ Compliant to RoHS (EU) and CRoHS (China). Usable on a global basis.

Technical Features

STRUCTURE

Product Line		Coaxial Cable Accessories
Type of Grounding Kit		Universal connector grounding kit
Transmission Line Type		LCF12, LCF78, UCF78, LCFS114, LCF158, LCF214
Cable Type		Coaxial Foam Dielectric, Ultraflexible Coaxial Foam Dielectric
Cable Size		1/2", 7/8", 1-1/4", 1-5/8", 2-1/4"
Number of Cable / Waveguide Runs		1
Material		Stainless Steel

TEMPERATURE SPECIFICATIONS

Installation Temperature	°C (°F)	-50 to 85 (-58 to 185)
Operation Temperature	°C (°F)	-50 to 85 (-58 to 185)
Storage Temperature	°C (°F)	-50 to 85 (-58 to 185)

PACKAGING INFORMATION

Package Quantity		1
------------------	--	---

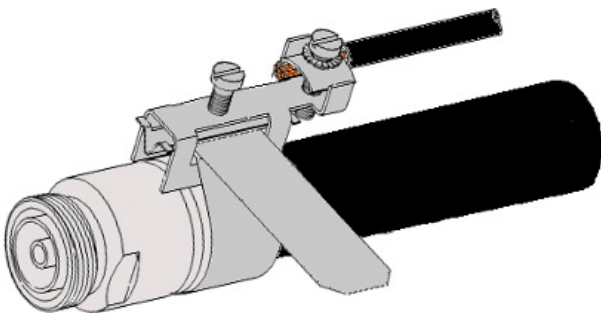

Instance of installation. The shown grounding wire is not included.

External Document Links

Notes